

IN-STEP INFLATABLE ANTENNA
EXPERIMENT

R. E. Freeland*
Jet Propulsion Laboratory
California Institute of Technology
Pasadena, California

G. Bilyeu**
L'Garde Incorporated
Tustin, California

Abstract

Large deployable space antennas are needed to accommodate a number of applications that include mobile communications, earth observation radiometry, active microwave sensing, **space-orbiting** very long baseline interferometry, and Department of Defense (DoD) space-based radar. The criteria for evaluating candidate structural concepts for essentially all the applications is the same; high deployment reliability, low cost, low weight, low launch volume, and high aperture precision. A new class of space structures, called inflatable deployable structures, have tremendous potential for completely satisfying the first four criteria and good potential for accommodating the longer wavelength applications. An inflatable deployable antenna under development by L'Garde Inc. of Tustin, California, represents such a concept. Its level of technology is mature enough to support a meaningful orbital technology experiment.

The NASA Office of Aeronautics and Space Technology initiated the In-Space Technology Experiments Program (IN-STEP) specifically to sponsor the verification and/or validation of unique and innovative space technologies in the space environment. The potential of the **L'Garde** concept has been recognized and resulted in its selection for an IN-STEP experiment.

*Manager, Technology Development for Space Antennas and Telescopes, Applied Mechanics and Technology Section

**Program Manager, Inflatable Antenna Experiment

The objective of the experiment is to (a) validate the deployment of a **14-meter**, inflatable parabolic reflector structure, (b) measure the reflector surface accuracy, and (c) investigate structural damping characteristics under operational conditions.

The experiment approach will be to use the NASA Spartan Spacecraft to carry the experiment on orbit. Reflector deployment will be monitored by two high-resolution video cameras. Reflector surface quality will be measured with a digital imaging radiometer. Structural damping will be based on measuring the decay of reflector structure amplitude.

The experiment is being managed by the Jet Propulsion Laboratory. The experiment definition phase (Phase B) will be completed by the end of fiscal year (FY) 1992; hardware development (Phase C/D) is expected to start by early FY 1993; and launch is scheduled for 1995.

The paper describes the accomplishments to date and the approach for the remainder of the experiment.

1. Introduction

Large space-deployable reflector antennas are needed for a variety of applications that require structures up to 40 meters in diameter for RF operation between 0.3 and 90 GHz. The applications include mobile communications, earth observation radiometry, active microwave sensing, orbiting very long baseline interferometry (OVLBI), and DoD space-based radar. Mobile communications system concepts are based on (a) L-band, 1.5 GHz with aperture sizes from 10 to 20 meters and (b) Ka-band, 20 to 30 GHz with apertures from 4 to 8 meters.^{1,2,3} Earth observation radiometry can

utilize reflectors from 20 to 40 meters in diameter operating somewhere between 6 and 60 GHz.^{4,5,6,7,8} Active microwave sensing is based on arrays from 0.4 by 2 meters and possibly up to 4 by 16 meters with an RF range from 1 to 94 GHz. The next generation OVLBI after the VLBI Space Observatory Program (VSOP) and RADIOASTRON has a baseline system concept of 20 to 25 meters in diameter with RF operation up to at least 43 GHz and possibly to 60 GHz.^{9,10,11} Current DoD concepts for space-based radar are based on structures from 20 to 30 meters in diameter for operation from 1.5 to 2.5 GHz.

The criteria for evaluating and selecting concepts for development and application to these classes of missions is essentially the same: high deployment reliability, low cost, low weight, and high aperture precision. Many of the current concepts, especially in the large size range, i.e. > 10 meters, are very innovative, but most of them are very complex mechanically.^{2,3,10,11,12} These concepts are based on a combination of a large number of structural elements, hinges, latches, actuators, springs, cables, panels, mesh shaping systems, and flexible RF reflecting surfaces. Consequently, such structures do not usually lend themselves to high deployment reliability, or low-cost applications. However, a new type of inflatable deployable reflector concept has emerged that has tremendous potential for satisfying three of the major criteria. A good example of this type of structure is the L'Garde parabolic, offset reflector concept. It has been developed to the point of ground-based demonstration hardware models up to 9 meters in diameter for the evaluation of manufacturing processes, assembly approaches, packaging techniques and deployment schemes. The current facilities of L'Garde can accommodate the development of inflatable structures up to 14 meters in size. However, the processing of materials and the fabrication and assembly techniques are nearly identical for inflatable structures from 10 to 30 meters. Therefore, demonstrations of hardware performance in this size range can be extrapolated to 30-meter structures. Meaningful ground-based hardware demonstration for this concept is not possible because gravity loading of the inflatable structure is greater than the inflation induced deployment loading in the vertical direction. Consequently, the technology data base for this concept is sufficient to accommodate the next logical step of development, which is a flight experiment based on a 14-meter structure.^{13,14,15,16}

The NASA Office of Aeronautics and Space Technology (OAST) is sponsoring the In-Space Technology Experiment Program (IN-STEP), which is intended to support low-cost, high-payoff flight experiments.¹⁷ Sponsorship of IN-STEP starts with experiment proposals generated in response to the NASA Announcement of Opportunity. Successful proposals are funded through the feasibility study phase (Phase A) for further evaluation by the NASA sponsor. Promising experiments are then funded through a Phase B that results in the experiment preliminary design, the Phase C/D program plan, and associated cost estimates, which is the basis of the data presented to the Non-Advocate Review Board. A recommendation by this board usually results in the initiation of Phase C/D. The L'Garde inflatable deployable reflector concept experiment proposal was selected in 1988 for Phase A development under the direction of the NASA Langley Research Center. Phase B was initiated in 1990 under the direction of the Jet Propulsion Laboratory. Phase B is scheduled for completion by August 1992 with the expectation of a Phase C/D start in late 1992 and a 1995 launch. This paper discusses the early results of the Phase B Study and the technical approach for the experiment.

2. Experiment Objectives

The objectives of the experiment are to (a) validate the successful deployment of a 14-meter-diameter, inflatable deployable, offset parabolic reflector structure in a zero g environment, (b) measure the reflector surface precision for several different sun angles and internal inflation pressures in a realistic gravity and thermal environment, and (c) investigate the structural damping characteristics of the fundamental modes of this type of unique structure, within the cost and schedule constraints of the IN-STEP program. The targeted cost for the Phase C/D hardware development, not including launch, is on the order of \$4 million. A space structure of this size for such a low cost is only possible because of the relative ease of designing, testing, and building this class of structure.

3. Technical Approach

The experiment will be attached to the Spartan recoverable spacecraft that will be taken to orbit by the space shuttle (the Space Transportation System or STS). Once on low earth orbit, it will provide (a) a mounting platform for the antenna and measurement system, (b) power, (c) attitude control, and (d) data recording. Deployment of the antenna

structure will be monitored by two high-resolution television cameras. The precision of the reflector surface, as a function of different sun angles and internal pressures, will be measured with a digital imaging radiometer. Estimates of the effective structural damping coefficients will be based on reflector structure motion as measured by reflector mounted piezo-electric transducers that produce a sinusoidal voltage decay with time.

4. Experiment Description

The antenna experiment orbital system configuration is shown in Figure 1. The basic elements of the system are the (a) inflatable torus, which is the support structure for the reflector, (b) the inflatable parabolic membrane reflector structure, (c) the inflatable struts, which have capability for supporting a feed or subreflector structure, but, for this experiment, terminate at the canister, (d) the canister, which interfaces the antenna experiment to the Spartan, supports the stowed antenna and other experiment equipment, and incorporates deployable doors to access the antenna to the space environment and provides mounting for the measurement system, (e) the instrumentation system that consists of high-resolution television cameras and a digital imaging radiometer, which are mounted in the canister, and

(f) the Spartan, which provides structural support to the experiment and initiation commands to the experiment controller.

The operational scenario of the experiment starts with the mounting of the experiment package to the Spartan at Goddard Space Flight Center (GSFC). The Spartan is then taken to Kennedy Space Center (KSC) for integration with the space shuttle. Once in low earth orbit, the Spartan is placed overboard with the Remote Manipulator System (RMS) and aligned with the velocity vector such that the Spartan is at the ram end of the system configuration and the high drag reflector structure is down stream. This orientation is expected to provide near passive attitude control during the experiment. Once the orbiter has moved a safe distance from the experiment hardware, a start command from the Spartan initiates implementation of the experiment (Figure 2). Antenna deployment commences with the opening of the primary canister cover door so that the stowed reflector structure is exposed to the space environment. Then the three side panels, which support the three legs of the strut structure, are free to open. Next, the inflation system provides nitrogen gas to the struts and torus, which are the basic reflector structure. Deployment is finalized by the inflation of the volume between the reflector membrane and the canopy. The entire

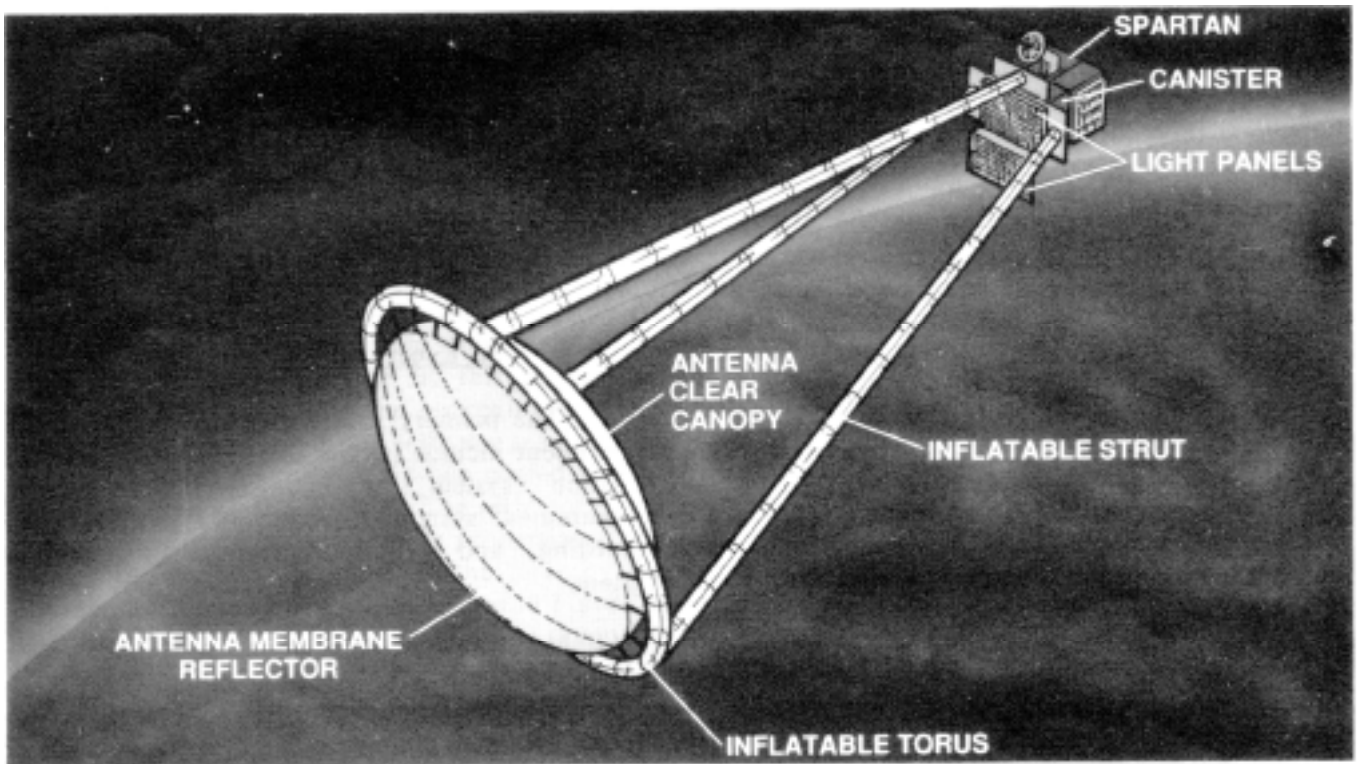

Fig. 1. Experiment Orbital Configuration

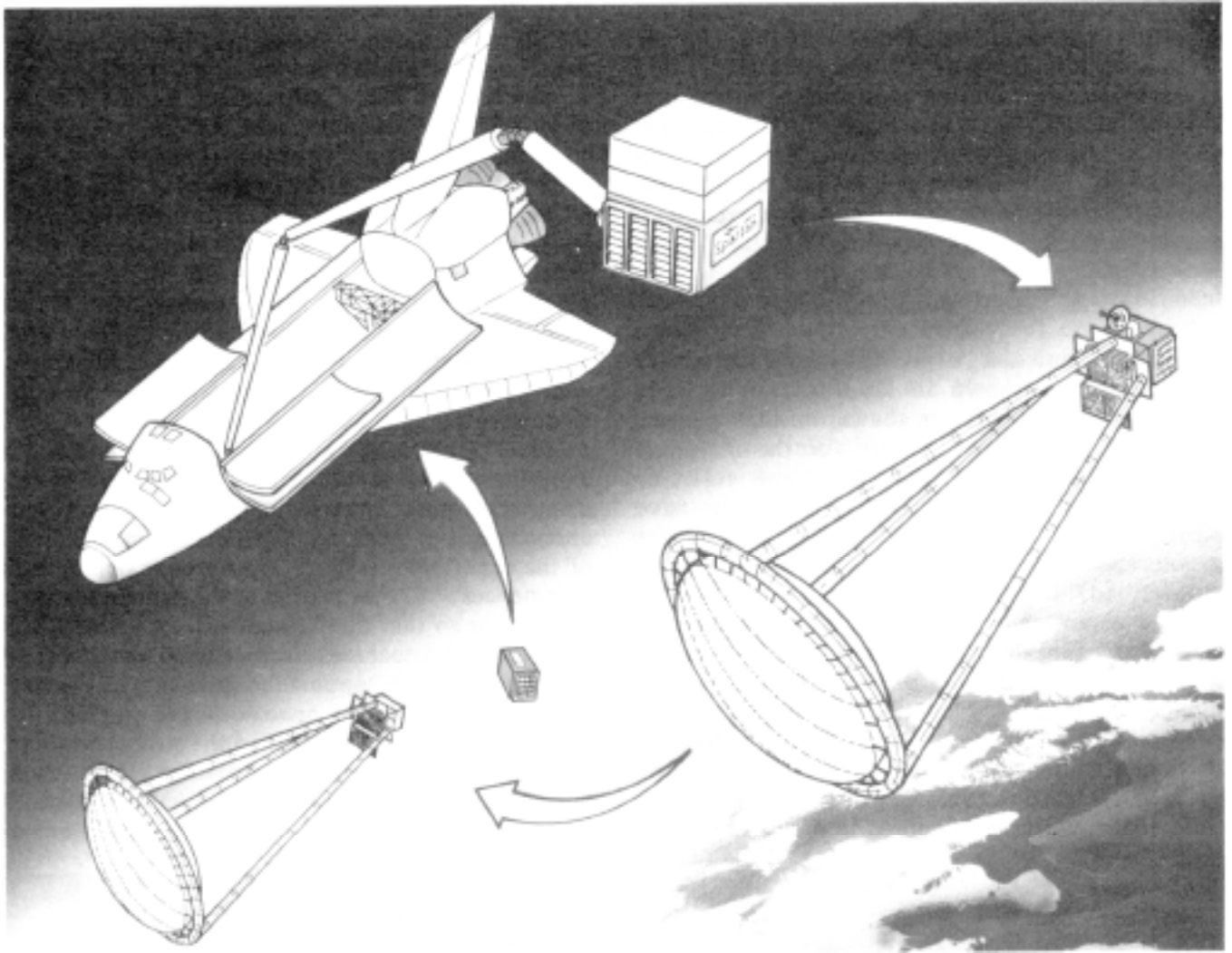

Fig. 2. Experiment Architecture

deployment sequence will take on the order of 10 minutes and will be observed by television cameras and recorded on video recorders. Because of the relatively high drag of the antenna, which will increase the separation distance between the Spartan and orbiter, the experiment will be completed in one orbit, then the antenna structure will be separated from the Spartan (Figure 3). Surface accuracy measurements will be made for five sun angles to get different temperature distributions. Three measurements will be made in the Earth's shadow at different pressures and the same temperature. The final step of the experiment is to employ the Spartan's attitude control system (ACS) to provide excitation of the structure and measure voltage output of piezo-electric transducers mounted to the structure. From the voltage decay versus time, the effective damping coefficient can be determined. All measurement data will be stored on tape recorders located in the Spartan. At this point the

antenna will be separated from the Spartan, which will be recovered by the orbiter at the end of its nominal mission.

5. Experiment Subsystems

The primary subsystems that comprise the experiment include (a) the inflatable structure, (b) inflation system, (c) canister, (d) surface measurement system, (e) controller unit, (f) data recording, and (g) Spartan/antenna separation system.

Inflatable Structure

The design goal for the reflector structure surface precision on orbit is 1 mm rms. To achieve this precision, the inflatable reflector assembly is made up of the reflector membrane and a canopy that are joined to form a lenticular structural

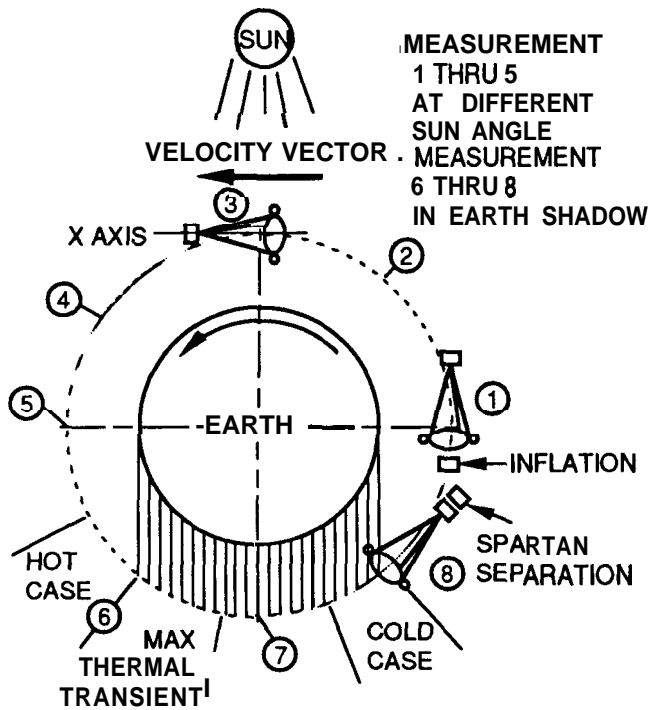

Fig. 3. Orbital Functional Sequences

configuration (Figure 4). The canopy is simply a mirror image of the reflector membrane but is clear to allow the surface accuracy measurement system light patterns to be seen by the television camera. Both the canopy and reflector are fabricated by joining flat, pie-shaped segments (gores) whose dimensions have been calculated using L'Garde's FLATE computer code. The gores are made from 6.35-micron Mylar film and are joined using Mylar tape. The reflector/canopy paraboloids are formed into a lenticular shape when the space between is pressurized to 5.52 Pa. The exact parabolic shapes are determined by the proper selection of gore dimensions, material mechanical properties, and the inflation pressure. The minimum stress in the Mylar gores is 6.89 MPa, because at this stress-level experience has shown that the packaging wrinkles are removed. The canopy and reflector are joined at their edge diameters with neoprene coated Kevlar doublers as shown in Figure 4. The reflector shape is maintained by the load carrying properties of the torus. The reflector is joined to the torus by the discrete, adjustable mechanisms shown in Figure 4. The proper edge flatness and diametrical shape are attained by adjustment of these mechanisms during factory assembly.

The feed support structure interfaces the reflector with the canister and consists of three

struts, which carry the load between the torus/reflector and the canister/Spartan during maneuvering. The torus small cross section diameter is 0.61 meters, and the diameter of the struts is 0.46 meters, and both are pressurized to 6890 Pa. Both the torus and the struts are fabricated using 0.3-mm neoprene rubber coated Kevlar fabric. Neoprene/Kevlar is being used because it is readily available, strong, leak-free, bondable, flexible, and reasonably priced. L'Garde also has extensive experience using this material for fabricating tori and cylinders for other programs. The total weight of the inflatable antenna structure is 60 kg.

Inflation System

The inflation system is housed within the canister and includes the valves, gas cylinders, filters, and regulators needed to provide inflation gas and maintain regulated pressures within the inflatable structures. The components used are (to the maximum extent possible) the same as those used in the Spartan attitude control system, thus minimizing the cost for new design and development. Opening the enable valve provides 21 MPa pressure to the system, which is regulated down to 414 KPa at the control valves. The selection of 414 KPa was based on previous experience. Analysis to establish the pressure for the preliminary design will be performed during the Phase B Study. The optimum regulated pressure will be that which allows precise pressure control to the struts and torus at the beginning of inflation and yet provides a sufficiently high flow rate to complete deployment within a reasonable time.

At the time the canister doors are opened the internal pressure of the inflatable must be zero, otherwise the inflation sequence will not function according to plan. Since it is impossible to keep the inflatable at zero pressure prior to launch, vent valves are provided downstream of the control valves. This allows the inflatable to vent during ascent. The valves are then closed just prior to inflation. These valves also serve as secondary shut-off valves should the enable valve and control valves fail to open.

The torus and struts will require 4.87 SCM of nitrogen while the antenna reflector will require 9.9×10^{-3} SCM for a total of $2.4 \times 10^4 \text{ cm}^3$ at 21 MPa. Using two of the Spartan attitude control tanks provides sufficient capacity to allow for changes that will result as the design matures.

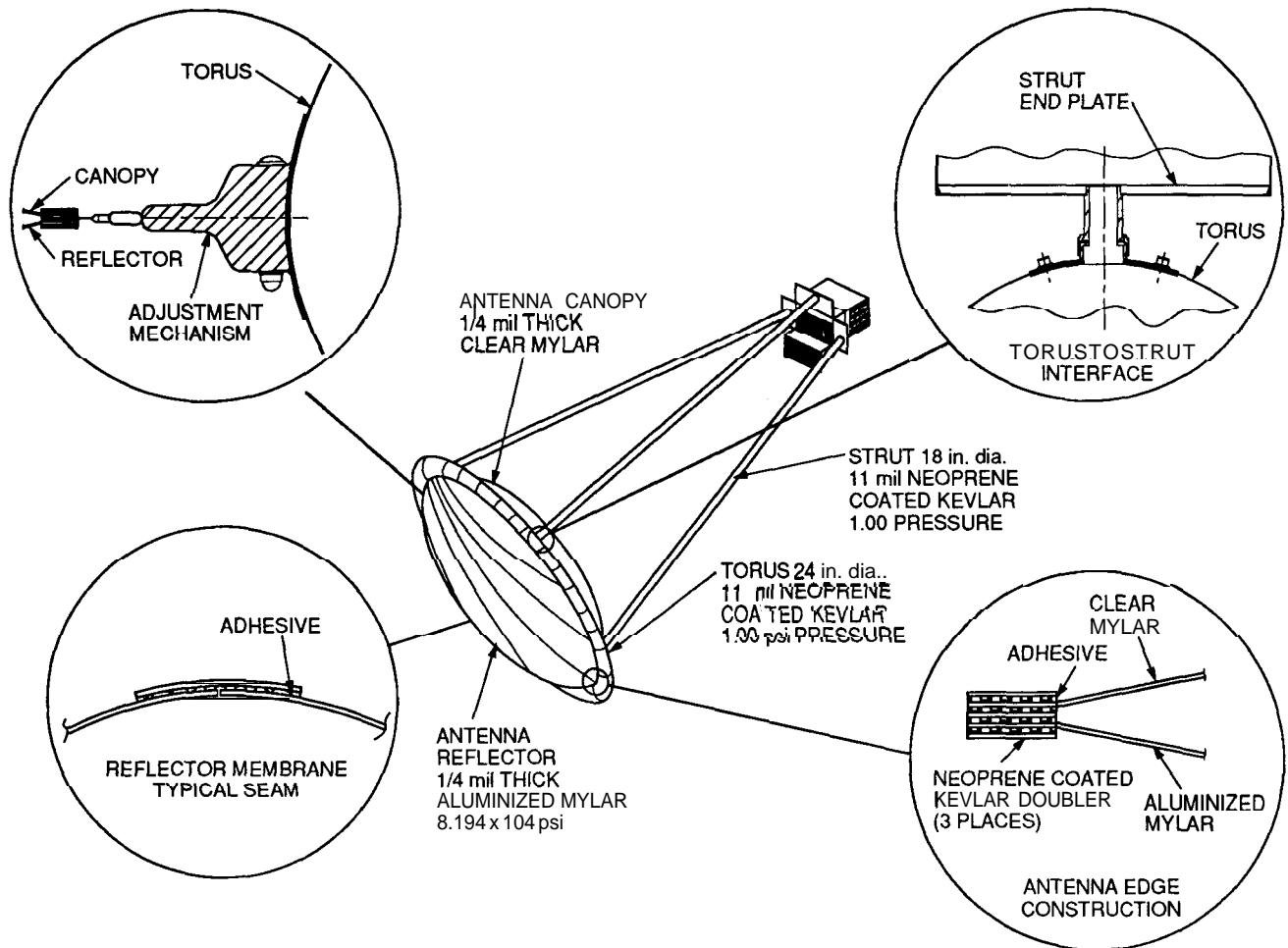

Fig. 4. Inflatable Structure Detail

Canister

The canister is made of honeycomb sandwich-constructed panels with aluminum core and face sheets. Honeycomb sandwich was selected because of its inherent stiffness and its characteristic smooth surfaces that will interface with the inflatable structure (Figure 5). The exact thickness of the panels will be established during detail design after the finite element structural model has been developed and the detail structural requirements determined. The primary loads will be those imposed by the STS launch and landing environments, which are relatively mild for this type of structure.

The canister primary cover door is held closed by a latch and pin puller that is a pyrotechnic actuated device. Upon command from the controller, the pyrotechnic will fire causing the pin to retract and release the doors. As the top door opens, the side door retention pins are released,

allowing the two side doors to open. These in turn release the front door allowing it to open. Once all doors are open and locked in place, the inflation sequence begins.

The three side doors of the canister provide the mounting surface for the inflatable struts that connect the reflector assembly to the spacecraft. The door-open positions are established with the use of the combination damper/positioner. To be assured of sufficient force to reliably open a door, a strong torsion hinge spring will be used. A damper is provided that will control the door velocity and reduce the impact force when it reaches the 90° position. The damper consists of a cylinder filled with silicon oil and pistons with small orifices. The orifices control the oil flow rate across the pistons, which will result in controlling the door velocity. At zero velocity the full spring force is available to open the door. When the damper reaches its full extension a zero back-lash latch locks the door in place.

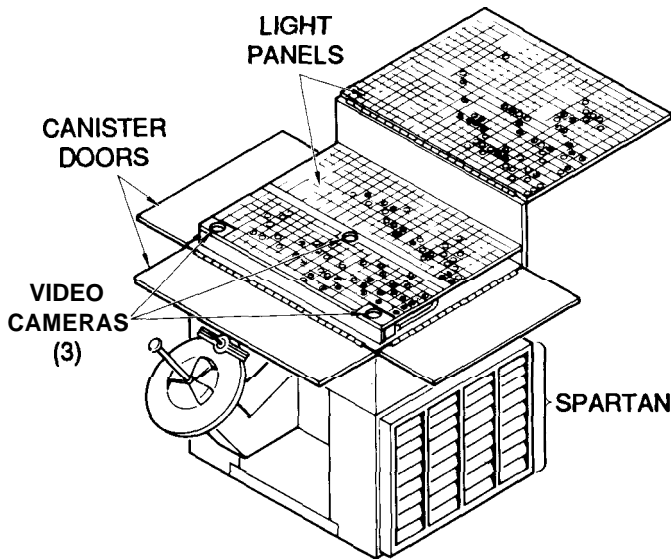

Fig. 5. Canister and Spartan

Surface Measurement System

The L'Garde Surface Accuracy Measurement System (SAMS) is an optical evaluation system based on the concept for McDonnell Douglas' Digital Imaging Radiometer.¹⁸ McDonnell Douglas developed this system for solar concentrator alignment for their terrestrial solar dynamic program.^{19,20} They called it the Digital Imaging Radiometer (DIR) because digital images of a concentrator were processed to measure its optical alignment. In a previous program, Deployable Solar Concentrator Experiment (DSCE), L'Garde has done a substantial number of reflector/antenna surface accuracy measurements using a specialized laser system. For the experiment, it is planned to use the SAMS to make accuracy measurements of subscale reflectors and compare results with the laser measurements of the same subscale reflectors. L'Garde's laser system has an accuracy of less than 0.1 mm. This will allow cross calibration of the two measurement systems. The experiment 14-meter reflector, although too large to be measured with the SAMS because of facility constraints, can be ground tested (calibrated) with the laser system setup. This approach will allow comparison of flight measurements and ground measurements.

The principle behind L'Garde's Surface Accuracy Measurement System is based on the laws of specular reflection. Figure 6 shows the reflecting surface, light sources, and the video/camera recorder. If the location of the light source, the camera, and the reflection point are known, there can be one and only one slope at the reflection point that would result in the reflected ray intersecting the

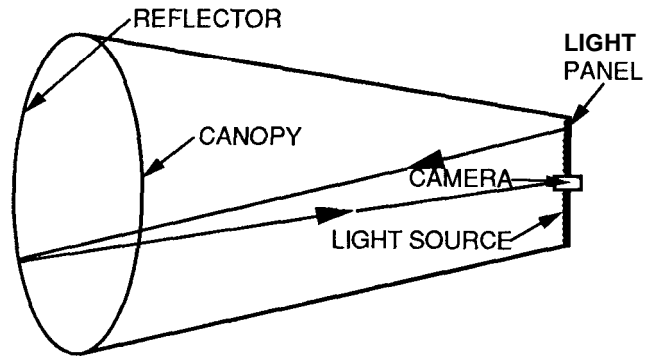

Fig. 6. Surface Measurement System Configuration (Not to Scale)

camera. In the ideal case, if the light source and the camera can be put in the same location — for example, at the center of a perfectly spherical mirror — the camera will see reflected light from the whole surface. For surfaces that are not perfectly spherical in shape, such as a parabolic reflector, the light sources and camera are positioned at a distance about equal to the average radius of curvature of the surface. The number of light sources and their spatial distribution, for the total surface to be imaged and measured to within a desired accuracy, depends on their distance from the reflecting surface, the system resolution, and the rms slope deviation of the surface from a perfect sphere. A large amount of surface data points may be collected from a single light flash because of surface imperfections, and, hence, hundreds of light returns are possible. Furthermore, because the sensing elements in the video camera are Charge Coupled Devices (CCDs), which are essentially metal oxide silicon (MOS) capacitors, and the light sources are Light Emitting Diodes (LEDs), the overall system response time is on the order of only a few milliseconds. Consequently, a large number of complete sets of measurements is possible in a short time. The experiment controller selects an LED to turn on, and transmits a digital coded message to the light switcher (a current source) that applies a current through the selected LED in the panel, turning it on. A number of reflective spots from the reflector are seen by the camera and recorded on video tape.

The areal size of the light panels can be minimized by proper selection of its distance from the reflector, which occurs at roughly the average radius of curvature of the parabolic reflector. The minimum number of light sources needed to measure the surface to a desired accuracy can be obtained by

applying statistical concepts. Intervals of **ninety-five** percent confidence have been determined for different configurations of light sources. The actual video image will be a small area (or areas, depending on the surface irregularities) of light on the antenna reflector surface. This small area of light comprises multiple pixels whose position can be determined relative to the overall antenna reflector. Knowing this information, the slope of the reflecting surface can be determined.

The reflector surface is determined using the following algorithm: (a) the coordinates of the light sources and the corresponding coordinates of their reflection points are obtained from the video data, (b) an initial starting estimate of the reflector shape is assumed, (c) from the data, the surface slopes are calculated, (d) the surface slopes, when integrated, give a refined shape, and (e) this surface shape is then used as the next starting point and iterated until convergence is achieved.

The light source consists of a 4-cm-diameter hemispherical dome on which are mounted 37 **LEDs** in hexagonal close-packing geometry. The LED is made from aluminum gallium arsenide (**AlGaAs**) emitting in the **660-nm** wavelength (red) and about **75-100 nm** wide. The optical output power from each LED is about **10 milliwatts** at a forward drive current of 30 milliamperes. The LED turn on voltage is 3.4 volts.

The candidate camera is a **VIDEOSPECTION** CCD camera with a resolution of 786 X 488 pixels. Its sensitivity is 10^{-3} lux. A band pass filter centered at 660 nm and 10 nm wide will be incorporated into the camera lens to filter out a major portion of the sun's energy. This camera has been qualified by NASA Lewis Research Center for shuttle use.

Con troller Unit

The microprocessor **L'Garde** is planning for the IAE is the Intel **87HC196** CMOS processor. This processor contains a full processor, both serial and parallel I/O, a sample/hold and A/D converter, and 8 kbytes of memory all on one chip. The associated circuits consist of a crystal oscillator to provide a precision time base for all of the system timing and sequencing controls, a power level sensor to detect power turn-on or low power, and various registers to interface with the light array, the power control drivers, and the pyrotechnic device drive circuits.

It has been planned that power for the microprocessor will be first initiated by closure of a mechanical switch on the Spartan carrier. The power level sensor will cause the microprocessor to be held in a reset condition until a fixed delay after the initiation of power. This will assure that the processor will start in an orderly manner. It will also monitor power throughout the mission, and if, for any reason, there is an interruption of power to the microprocessor, the monitor circuit will again assure that the microprocessor restarts in an orderly fashion.

The processor requires a clock for its operation. There are a number of options that are available for use to provide a clock, including a built-in clock circuit. In this application, the microprocessor will be the primary time-keeping element. All sequencing will be done by the processor, using the clock as the time reference. For the preliminary design, it has been decided to obtain the clock from an oscillator circuit rather than some of the other options that are less accurate.

The control of devices outside of the microprocessor is accomplished by writing data to the various registers associated with the processor. The data contained in those registers is decoded and appropriately routed to the control devices. The functions that will be performed by the controller include (a) light panel sequencing for the surface accuracy measurement system, (b) control of the pyrotechnic devices used to accommodate the antenna deployment sequence, (c) control of the dynamic actuator used to perturb the reflector membrane for motion decay tests, (d) control of the inflation pressure as a function of time, (e) video camera synchronization to a common time source, (f) control of the three video cameras and video recorders, and (g) health monitoring of the electronics system.

Data Recording

Data recording will be accomplished using the three video recorders and the digital data recorder located on the Spartan. One video recorder will be used to view the near-field inflation process and another video recorder will be used to view the far-field inflation process. The third video recorder will record the data from the surface accuracy measurement system. All video recorders will be retrieved with the Spartan vehicle. The digital data recorder is existing Spartan equipment that will be utilized for recording the various timed events,

power levels, pressure levels and variations, temperatures, and other transducer output. Spartan attitude and orbital position data will also be recorded by the digital data recorder. Data reduction will be a part of the post-flight activities. No real-time data reduction is planned.

Spartan/Antenna Separation System

At the conclusion of the experiment, the antenna will be separated from the Spartan by means of pyrotechnically releasing the interface attachment bolts and then letting the drag forces on the reflector structures separate it from the Spartan. This separation system will be an integral part of the Spartan Spacecraft and actuated by command from the Spartan.

6. Reflector Mechanical Characteristics

The reflector orbital thermal and structural performance is being characterized analytically to accommodate the preliminary design and estimate the experiment performance parameters. These preliminary estimates will be refined with the results of the detail design, analysis, and ground-based developmental testing.

Reflector Thermal Characteristics

The Parabolic Antenna Temperature (PANT) Code is a specialized thermal analyzer code designed and optimized for symmetric thin-film paraboloid-cone-shaped geometry space reflectors at steady state thermal conditions.²¹ The clear canopy is assumed to be a cone in this analysis approach. This minor deviation from the actual hardware configuration is not considered significant. PANT calculates the radiative heat exchange among the surfaces making up the paraboloid-cone system. It also includes a ray tracing feature that calculates the net energy received by surface elements as a result of **nonzero** material solar transmissivities. This feature may be turned off by inputting zero transmissivity values. Figure 7 shows the general paraboloid cone antenna and the coordinate system used to describe it. The surface area of the system in Figure 7 is automatically divided into a number of discrete elements, much like in a finite element or finite difference analysis. The radiant energy exchange between these elements is then calculated and the temperatures of each of the elements is saved. In order to be able to use PANT to analyze the **14-meter** reflector, we approximate the off-axis

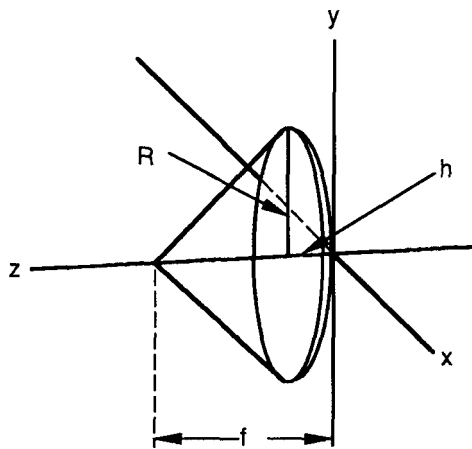

Fig. 7. Thermal Analysis Antenna System Model

paraboloid by an on-axis reflector with approximately the same surface area. The on-axis model parameters have also been chosen so that the cone will have approximately the same surface area as the canopy. For the flight experiment confirmation, the reflector-canopy parameters are:

Reflector	Canopy
Focal length: 14.0 m	Focal length: 4.0 m
Diameter: 14.0 m	Radius: 7.0 m
Surface Area: 147.0 m ²	Surface Area: 157.0 m ²

The thermal model used by PANT, showing the discretization scheme, is depicted in Figure 8, which, however, has only a total 110 elements. In

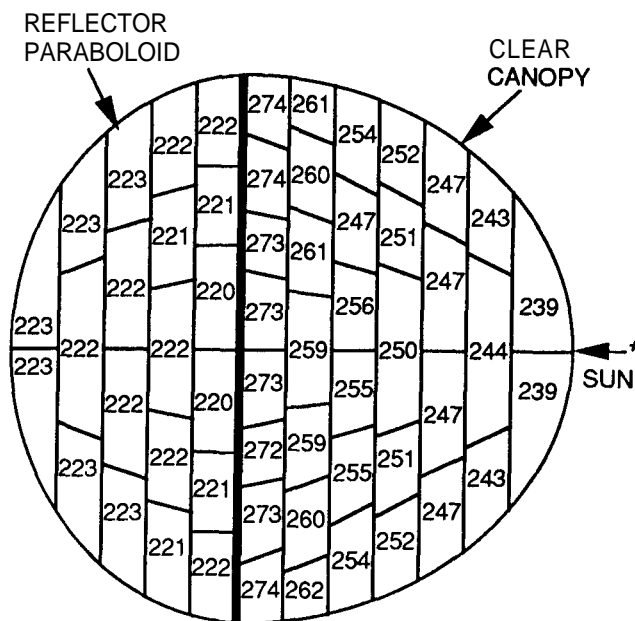

Fig. 8. Reflector Temperature Distribution (°K)

the analysis, PANT actually used 476 radiative elements and 100,000 Monte Carlo rays for ray tracing. Figure 8 indicates the temperatures of the elements for a solar angle of zero. This Thermal model, using the optical properties of the Mylar membrane material, was used to project the thermal profile over the reflector surface. Figure 9 shows the approximate temperatures across the reflector surface at different solar aspect angles. As can be seen, there is a wide temperature variation with solar angle. Ideally, for operational conditions we want a constant temperature that is independent of the sun angle with zero thermal gradient. The maximum temperature variation in Figure 9 occurs at a solar aspect angle of $\beta = 90^\circ$, which is about 115 K. Previous thermal analysis of this type of structure has shown that the temperature gradients over the solar illuminated portion of the reflector are low, because of the relatively flat geometry and the very short thermal time constant for this thin material.

The surface of the antenna canopy system may be appropriately coated with paint, for example, to obtain optimum optical properties so that the temperature excursions are minimized. However, in the flight experiment, we must have a clear canopy because we need to measure the surface accuracy using visible light. This puts a constraint on the optical properties of the canopy. At the temperatures shown, the allowable tensile stress of Mylar ranges between 27 MPa to 103 MPa. This is more than adequate for the flight experiment. Preliminary evaluation indicates that the reflector thermal distortion for a "sun on" condition will be only a fraction of a millimeter.

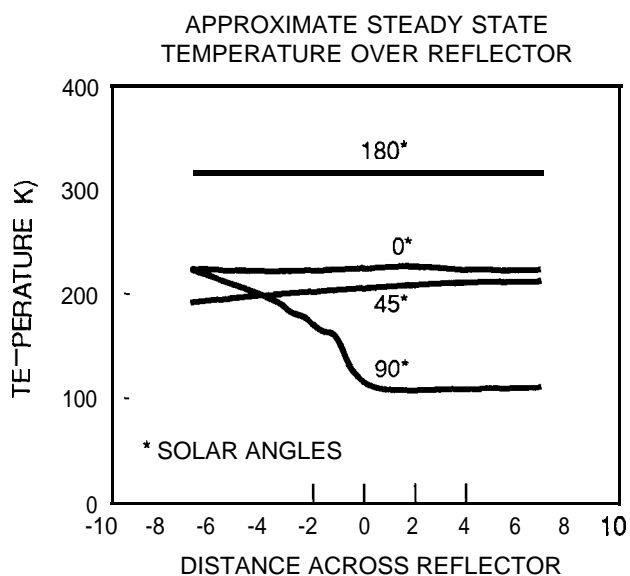

Fig. 9. Reflector Orbital Temperatures

Reflector Structural Characteristics

Figure 10 shows the finite element discretization of the inflatable antenna structure. It consists of the torus and three struts and assumes a series of rigid masses for the reflector and canopy membranes. It consists of 1110 isoparametric elements, and 3366 nodes. The shell element used is an eight node quadrilateral 3D shell element. It has six degrees of freedom per node — three displacements and three rotations. The loadings come from (a) the internal pressures in the struts and torus for 6.9 KPa, (b) an angular acceleration of 0.17 degrees/sec² about any three perpendicular axes through the center of mass of the SPARTAN, and (c) forces exerted on the torus rim by the reflector/canopy elastic interaction.²² The maximum stresses, as a result of these loadings, are on the order of 8.3 KPa and are well below the yield strength of the neoprene-coated Kevlar material.

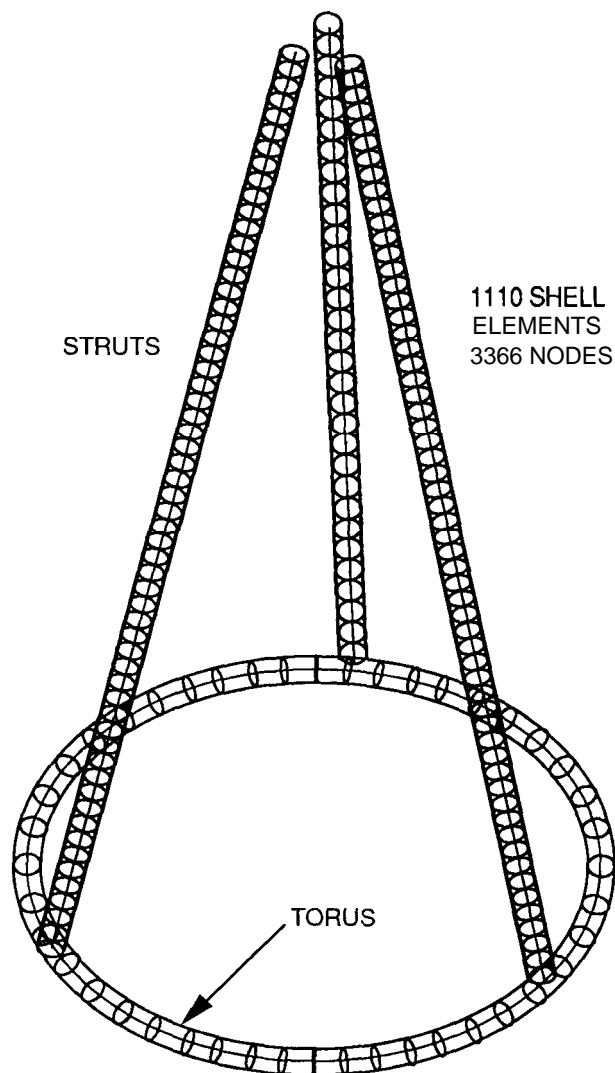

Fig. 10. Basic Structural Analytical Model

Initial analytical results indicate a fundamental frequency of the inflatable antenna structure of approximately 4 Hz. This mode is primarily bending of the struts with minimal elastic participation of the torus structure. The next level of analysis is directed toward including the elastic properties of the reflector/canopy structure in the model.

7. Ground-Based Test Program

The ground-based test program will include (a) typical environmental and functional tests of components, assemblies, and subsystems and (b) special development tests that include mechanical packaging verification, canister door opening tests, initial deployment evaluation, and surface measurement system calibration and verification.

Deployment Tests

The canister doors will be tested to evaluate and validate opening time, velocity, latching, and associated shock loads. Mechanical packaging techniques will be verified by using a full-size inflatable structure and a simulated canister. Deployment characteristics, under vacuum conditions, will be assessed with a 3-meter inflatable scale model.

Surface Measurement System

Light panel testing will be accomplished to demonstrate light source sequencing, optical output variations, and phasing with the video camera. Because of facility limitations, a 3-meter reflector will be used to calibrate the system. Testing will simulate earth shadow, full sun, and several solar aspect angles to validate system operation.

8. Program Status

The Phase A Study was initiated in FY 1988 and completed FY 1989. The Phase B Study was initiated in FY 1991 and will be completed late FY 1992. A successful conceptual design review was held in mid FY 1992. The non-advocate review will be held in late FY 1992. Phase C/D is expected to be initiated in early FY 1993 and launch in late FY 1995. Post flight data analysis should be completed by early FY 1996.

9. Conclusions

Study results to date clearly indicate that the technology for implementing this experiment is

mature and available for application. Results of the experiment will establish and characterize the performance of this new class of space structures. Additionally, the experiment data base will make possible design refinement of the basic concept and projections of performance for larger size structures in a variety of different service orbits.

Acknowledgments

The research described in this paper was carried out at the Jet Propulsion Laboratory, California Institute of Technology, under a contract with the National Aeronautics and Space Administration.

The authors would like to acknowledge the following individuals for their contribution to the development of the experiment definition; A. B. Chmielewski of JPL for providing an effective interface with the NASA sponsor; D. Carson of the Spartan Project Office at the NASA GSFC for the development of a Spartan carrier configuration to accommodate the experiment; G. Veal of L'Garde, the experiment principal investigator; and A. Palisoc, M. Thomas, T. Dagget, and G. Friese of L'Garde for the experiment development and significant contributions to this paper.

References

1. Naderi, F., editor, *Land Mobile Satellite Service (LMSS): A Conceptual System Design and Identification of the Critical Technologies*, JPL Publication 82-19, Jet Propulsion Laboratory, Pasadena, CA, Feb. 1982.
2. Freeland, R. E., "Spacecraft Antenna Technology Assessment," Chapter 4, JPL Internal Document D-5990, *Personal Access Satellite System Concept Study*, edited by M. K. Sue, Jet Propulsion Laboratory, Pasadena, CA, Feb. 1989.
3. Sue, M. K., editor, *Personal Access Satellite System (PASS) Study*, JPL Internal Document D-7382, Jet Propulsion Laboratory, Pasadena, CA, Sept. 1990.
4. Stutzman, W. L., and Brown, G. S., *The Science Benefits of and The Antenna Requirements for Microwave Remote Sensing from Geostationary Orbit*, NASA Contractor Report 4408, prepared for NASA Langley Research Center, Hampton, VA, Oct. 1991.

5. Garrett, L. B., editor, *Global Change Technology Architecture Trade Study*, NASA TM- 104128, 1991.
6. Rogers, C. A., W. L. Stutzman, T. G. Campbell, and J. M. Hedgepeth, "Mission to Planet Earth Technology Assessment and Development for Large Deployable Antennas," presented at the International Astronautical Federation, Dresden, GDR, Oct. 1990.
7. Campbell, T. G., editor, *NASA Workshop on Earth Sensing Geostationary Platform Technology*, Conference Proc. Publication 3040, NASA Langley Research Center, Hampton, VA, Sept. 1988.
8. Gasiewski, A. J., and D. H. Staelin, "Science Requirements for Passive Microwave Sensors on Earth Science Geostationary Platforms," *Proc. of the Workshop on Earth Science Geostationary Platform Technology*, NASA Conference Publication 3040, NASA Langley Research Center, Hampton, VA, 1988.
9. Jordan, J. F., Freeland, R. E., Levy, G. S., and Potts, G. L., "QUASAT - An Orbiting Very Long Baseline Interferometer Program Using Large Space Antenna Systems," *Large Space Antenna Systems Technology - 1984*, NASA Conf. Pub. 2368, Part 1, NASA Langley Research Center, Hampton, VA, pp. 117- 126, Dec. 1984.
10. Freeland, R. E., *QUASAT Antenna Technology Study*, JPL Internal Document D-3292, Jet Propulsion Laboratory, Pasadena, CA, Sept. 1986.
11. Levy, G., editor, *Workshop Proceedings: Technologies for Advanced Very Long Baseline Interferometry Missions in Space*, JPL Internal Document JPL D-8541, vol. 3, Jet Propulsion Laboratory, Pasadena, CA, Sept. 15, 1991.
12. Freeland, R. E., "Survey of Deployable Antenna Concepts," *Large Space Antenna Systems Technology - 1982*, NASA Conf. Pub. 2269, Part 1, NASA Langley Research Center, Hampton, VA, pp. 381-421, Dec. 1982.
13. Freeland, R. E., "Deployable Antenna Concept Development," presented at the AIAA Space Systems Technology Workshop III, Kirkland Air Force Base, Albuquerque, NM, Mar. 1984.
14. Springett, J., Freeland, R., Smith, J. G., and Woo, K., "Large Deployable Antenna Shuttle Experiment," presented at the American Astronautical Soc. Twenty-First Ann. Meeting on Space Shuttle Missions of the 80s, Denver, CO, Aug. 1975.
15. Mankins, J. C., Dickinson, R. M., Freeland, R. E. Marzwell, N. I. "Large Space Reflector Technology on the Space Station," AIAA Paper 86-2302, presented at Space Station in The Twenty-First Century, Reno, NV, Sept. 5, 1986.
16. Freeland, R. E. "Mobile Communications Satellite Antenna Flight Experiment Definition," IAF paper 87-314, presented at the 38th IAF International Astronautical Congress, Brighton, England, Oct. 10-17, 1987.
17. Clark, L. G., "A Look at NASA's IN-SPACE Technology Experiment Program," presented at the Canaveral Council of Technical Societies, Twenty-Seventh Space Congress, Cocoa Beach, FL, Apr. 1990.
18. Knapp, W., *The Digital Image Radiometer (DIR) Optical Evaluation System*, NASA Preliminary Information Report, PIR#189A, Apr. 12, 1990.
19. Blackmon, J., "Development and Performance of a Digital Image Radiometer for HelioStat Evaluation at Solar One," *Proc. of the ASME Solar Engineering Division Sixth Annual Conference*, Las Vegas, NV, Apr. 8-12, 1984.
20. Blackmon, J, et al., "Design and Performance of a Digital Image Radiometer for Dish Concentrator Evaluation," *Solar Engineering 1987*, Goswami, Watanabe, and Healy, editors, ASME, NY, pp. 318-323, vol. 1, 1987.
21. Palisoc, A., "PANT Analysis of 28 m Reflector for LINX," L'Garde Memo, LM-91-AP-143, June 1991.
22. Grossman, G., *Analysis of Loads in Rim Support of a J-J-Axis Inflatable Reflector*, L'Garde Technical Report, LTR-87-GG-041, Dec. 1987.