

A NOVEL, LIGHT WEIGHT SOLAR ARRAY:  
COMPARISON WITH CONVENTIONAL SYSTEMS

George J. Vendura, Jr.  
SUMM Associates, P. O. Box 124, Los Alamitos, CA 90720  
Patrick Malone  
L'Garde, Inc., 15181 Woodlawn Ave., Tustin, CA 92680  
Larry Crawford  
Phillips Laboratory, Kirtland AFB, NM87117

ABSTRACT

A novel, lightweight solar panel design is described incorporating the best features from three separate areas of development: 1) advanced solar cells 2) light weight, flexible blanket technology and 3) deployment by inflation.

Inflation deployed panels of various powers incorporating four different types of low mass solar cells are studied with respect to conventional systems. Depending on panel size and cell type, five-fold and three-fold improvements in specific powers (W/kg) can be realized compared to present state of the art rigid and flexible systems respectively.

INTRODUCTION

The interest in the development of reliable, light weight solar arrays in the range of 0.3 to 5.0 kilowatts is intense. Focus continues on increased payload to mass ratio, independent of the method of launch, deployment mechanism, orbit specification and panel size. The Advanced Photovoltaic Solar Array (APSA) for example, concentrates on a 11.6 Kw. system [1-2], while the power requirements for the smaller satellites of the Iridium program of Motorola are much more conservative. In either case, the ultimate goals for the entire system - cells, panel and deployment hardware - remain high power density (W/m<sup>2</sup>) and high specific power (W/kg).

This comparison study focuses upon maximizing these values by incorporating the best features of three separate areas of development:

- 1) advanced solar cells
- 2) light weight flexible blanket technology
- 3) deployment by inflation

Solar cells include conventional devices, thin silicon (Si) and gallium arsenide on germanium (GaAs/Ge), as well as emerging technologies, cleft gallium arsenide (C/GaAs) and copper indium diselenide (CIS).

The blanket design incorporates the best features of the APSA program: Kapton material, adhesives, circuit elements, hinge design, etc. However, the size is scaled down and details in the final layout differ amongst cell types to take advantage of each particular device's characteristics.

Independent of cell choice, deployment of the resulting blanket array is considered by means of an

inflatable framing structure or torus within which the panel remains suspended. Development of such an Inflatable Torus Solar Array Technology (ITSAT), is well underway [3-4]. A key feature is that the frame can be engineered to become permanently rigid in space, thereby eliminating the need for sustaining gas and supplemental supporting hardware.

There are numerous advantages to such an inflatable deployment system. Besides lower weight and increased power, the technique is low cost and reliable. The system has a minimum of complex parts and stows efficiently. Most importantly, both concept and materials have been proven in space. Similar inflatable structures in the forms of both targets and decoys are routinely launched and deployed, and the space deployment of an inflatable antenna is imminent. Lifetimes of three to five years are standard. Longer missions are possible with further development.

In this study systems in the 0.3 to 5.0 kW. range combining the best elements of cell, blanket and deployment technologies are designed and analyzed for both low earth (LEO) and geosynchronous (GEO) environments. Results in terms of specific power are compared to flexible arrays involving BI-STEM and astromast deployment as well as to a typical rigid panel, latch and spring deployed, such as DSCS III.

SOLAR CELLS

A schematic of the four different types of solar cells used in this study is shown in Figure 1. For simplicity only the basic elements of active volume, A, and substrate, B, are included. Coverglasses, metallization patterns and other fabrication features are not detailed.

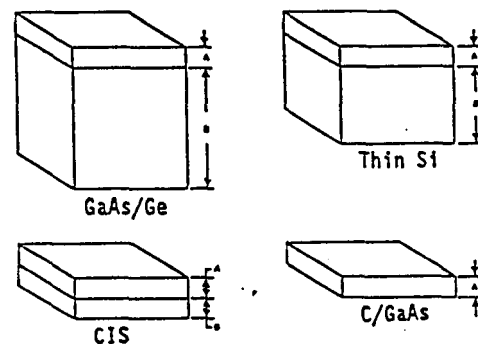

Figure 1. Cross Section of Lightweight Cells  
(Not to Scale)

As illustrated, even the thinnest available GaAs/Ge cells still require relatively massive Ge crystal substrates upon which the active layers are grown by an MOCVD technique. To lower weight, the Ge may be chemically or mechanically milled. The thickness of the cells used in this study is 3.5 mils.

Si cells also require heavy crystalline substrates. Active layers, however, are driven into the crystal's surface at high temperatures via a gaseous diffusion technique. Substrate material can be subsequently removed resulting in a cross section of 2.2 mils.

CIS cells are formed by the evaporation or sputtering of thin films onto various support materials. Substrates can be thick or thin, flexible or inflexible, metallic or plastic. In addition, deposition can occur over relatively large areas. The resulting thin film devices require no expensive crystalline support. In addition, they are capable of being combined into arrays by inexpensive integrated circuitry processes [5]. Yet, despite these potential advantages, CIS cells remain in the developmental stage. As such they are not available in quantity with large areas. Therefore for the purpose of immediate relevancy, this study focuses on CIS cells currently available: discrete devices, small (1.0 x 1.0 cm.), deposited on 1.0 mil titanium foil. The cells are individually (manually) interconnected.

C/GaAs cells are similar to GaAs/Ge except that the massive crystalline substrate is permanently removed (cleft). The resulting extremely thin active volume requires no supporting substrate [6]. (A glass superstrate, not shown, is necessary, but this structure serves as the radiation filter that would have been required anyway).

A summary of features of the solar cells used that impact packing and weight is given in Figure 2.

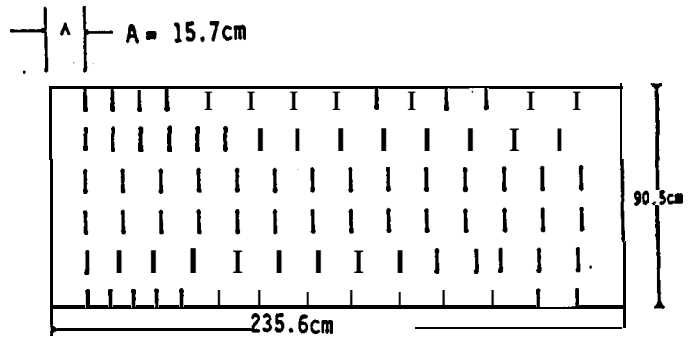

Figure 3. Baseline Blanket Design

POWER PREDICTIONS

Beginning of life (BOL) and end of life (EOL) power densities are calculated for the two missions outlined in Figure 4. To accomplish this the blanket described in Figure 3 and its multiples are assumed to be populated by the four types of cells using established fabrication practices. For example, 2.5 cm. of the overall length of the blanket is allocated for the array's electrical harness. For Si, GaAs/Ge and C/GaAs cells a 1.0 cm. border is allowed for the other three sides of each subpanel with 30 mil spacings between devices. The resulting packing factor is 0.8424. CIS cells, on the other hand, due to their thinness, the fact that they require no covers and their superior flexibility, tolerate narrower borders and closer cell to cell spacing. As a result, the CIS packing factor is 0.9430.

Type	Dimensions (cm x cm)	Substrate/Substrate Thickness (mils)	Coverglass Thickness (mils)	Stack Weight (kg/m <sup>2</sup> )
Thin Si	2.00 x 5.68	Si/2.2	2	.3651
GaAs/Ge	2.00 x 4.00	Ge/3.5	3	.8033
C/GaAs	2.00 x 4.00	NA	3	.3100
CIS	1.00 x 1.00	Ti/1.0	0	.1364

Figure 2. Baseline Solar Cells

BLANKET

The blanket design, although much smaller than the astronaut-deployed APSA, incorporates many of its light weight features. It too consists of 2.0 mil Kapton, accordion folded along thermocompression creases. The blanket, shown in Figure 3, is divided into 15 identical subpanels by 14 folds (dotted lines). The total area of this baseline blanket is 2.13 m<sup>2</sup>. However, multiples of this basic unit are also included in this investigation to analyze the performance of larger arrays. In total, five areas are considered: 2.13, 4.26, 8.52, 17.04 and 34.08 m<sup>2</sup>.

ORBIT	LEO	GEO
Altitude(km)	740	35,794
Orientation	Polar(90°)	Equator(0°)
EOL Power(w)*	100-200	100-200
Duration (yr.)	3.0	3.0
Orbit Duration	100 min	24 hr
Eclipse Duration	34 min	1.2 hr
Eclipse Cycles/3yrs	15,330	264
Temperature Extremes °C	+00/-00°	+45/-170°

\* per wing

Figure 4. Baseline Missions (Orbits)

For BOL predictions, assembly and temperature losses are computed. EOL power involves different temperatures as well as a radiation degradation factor due to omnidirectional protons and electrons. For partial protection GaAs (both Ge and cleft), Si and CIS cells are assumed to have cover glasses of 3, 2 and 0 mils respectively. EOL figures also include an additional "combined losses" factor to account for power degradation due to UV, cycling fatigue, and cover/adhesion darkening. These factors are summarized in Figure 5. The total array power is a function of the power density figures of the last column multiplied by the areas of the five blanket systems.

	Cell Efficiency %	Packing Factor %/100	Assembly Losses Factor %/100	Orbit	Temp. Factor %/100	BOL array n %/100	BOL Power Density w/sq.m	Combined Losses Factor %/100	Temp. Factor %/100	Radiation Factor %/100	EOL Array n %/100	EOL Power Density w/sq.m
Thin Crystal Si	13.8	0.842	.943	GEO	.975	10.64	144.64	.983	.935	.962	9.69	131.11
				LEO	.800	8.77	118.66	.983	.760	.892	7.30	98.77
GaAs/Ge	18.5	0.842	.943	GEO	.950	13.98	180.88	.983	.930	.960	12.90	174.54
				LEO	.863	12.68	171.56	.983	.843	.901	10.97	148.42
Cleft GaAs	18.5	0.842	.943	GEO	.950	13.98	188.88	.983	.930	.948	12.74	172.37
				LEO	.863	12.68	171.56	.983	.843	.852	10.38	140.44
CIS	11.0	0.843	.943	GEO	.981	9.00	129.89	.988	.973	.990	9.31	125.96
				LEO	.844	8.26	111.76	.988	.838	.990	8.00	108.24

Figure 5. BOL/EOL Power Densities

#### DEPLOYMENT BY INFLATION

The inflatable deployment structure consists of a tube or torus composed of an aluminum-plastic laminate. The cross section of the torus itself is round, 4.0 in. in diameter, but the overall shape of the supporting structure is a rectangular frame within which the blanket array is suspended. A schematic of the arrangement in partially and fully extended modes is shown in Figure 6. As illustrated, the lengths of the torus and blanket are folded together into a unit suitable for compact stowage. Besides the array, deployment components contributing to weight include the stowage box, a small gas canister, valves, cables and mounts.

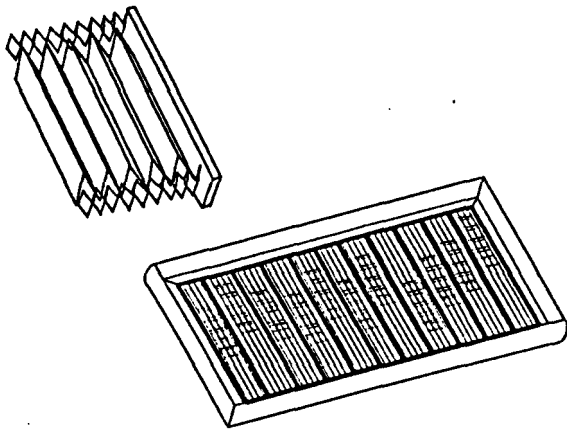

Figure 6. Inflatable Framing Structure and Panel

Actual deployment is effected through the temporary introduction of nitrogen or some other gaseous species. Because permanent rigidization of the torus is possible, the presence of sustaining gas is not required. Such rigidization is accomplished by an episode of overpressure that stresses the torus' laminate material into a permanently fixed configuration.

Gas rate of flow can be controlled for smooth, continuous deployment. Light weight guide wires, not shown, interconnecting various parts of the torus frame under the array, minimize undesirable out-of-plane excursions.

The true measure of any deployment system, inflation or other, is the relationship of the areal density with

respect to panel power. Areal density is the weight of the entire system (cells, blanket, torus and supporting deployment hardware) per unit area of deployed array ( $\text{kg}/\text{m}^2$ ). It is calculated for each of the five panel areas under consideration. Increases in the weight of deployment for the larger arrays are not derived by simple scale up. Instead, for accuracy, the actual changes in the required supporting hardware are considered and incorporated. The resulting areal densities are then combined with the corresponding BOL and EOL power densities in  $\text{W}/\text{m}^2$  to yield specific powers in  $\text{W}/\text{kg}$ .

Resulting specific powers are plotted against total array power in Figures 7 through 10. From these it can be concluded that, in general, higher performance appears to be eventually achievable using the developing CIS and C/GaAs cell technologies. Meanwhile, however, of the two device types presently space qualified, thin Si is clearly superior to GaAs/Ge.

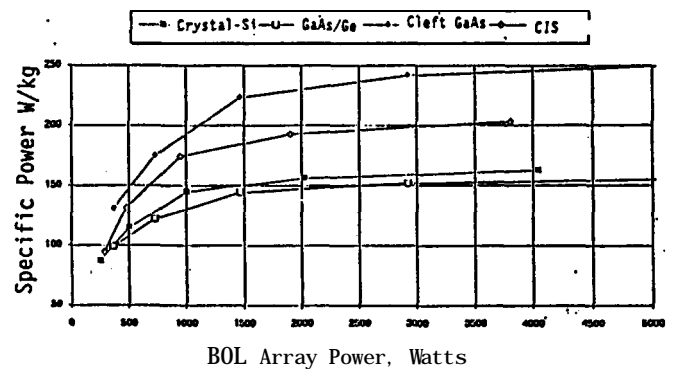

Figure 7. BOL/LEO (3 Years) - Specific Power vs Array Power

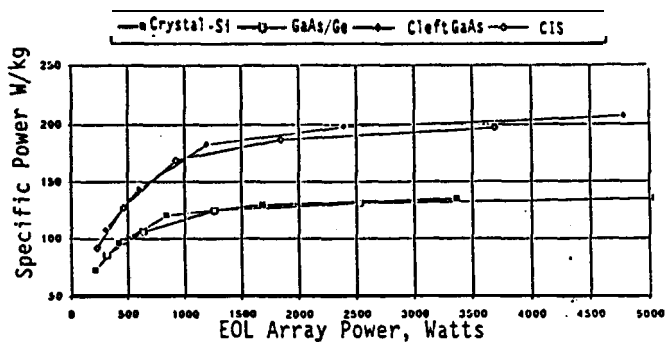

figure 8. EOL/LEO (3 Years) - Specific Power vs Array Power

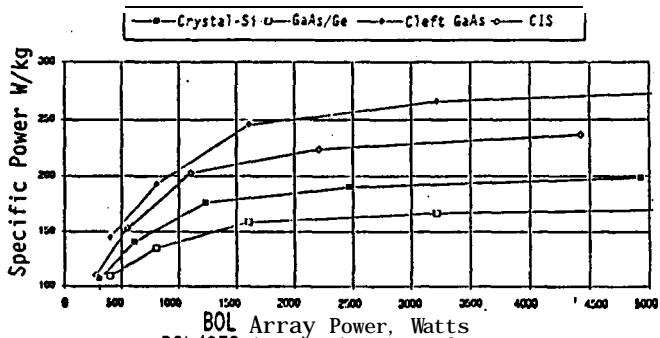

Figure 9. BOL/LEO (3 Years) - Specific Power vs Array Power

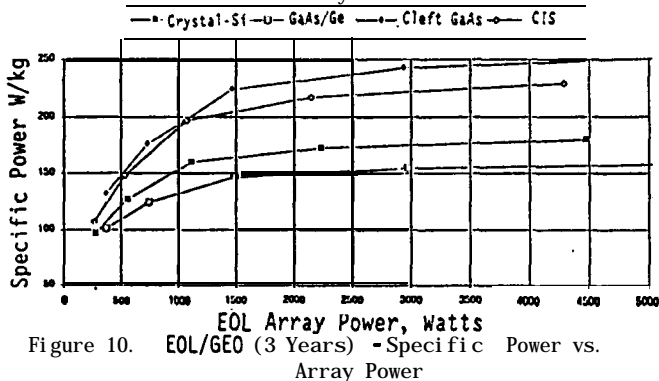

Figure 10. EOL/LEO (3 Years) - Specific Power vs Array Power

### DEPLOYMENT COMPARISON

Deployment by means of an ITSAT system is compared with three alternate methods: BI-STEM, astromast, and DSCS III. For simplicity with each, only the case of arrays consisting of thin Si solar cells is explored. Here the ITSAT, BI-STEM and astromast systems involve identical flexible blanket panels as previously described. DSCS III, on the other hand, uses a similar geometrical and power layout but on a standard, rigid panel platform constructed of a half inch aluminum honeycomb core, 8 mil Al face sheets and conventional adhesives.

BI-STEM (Storable Tubular Extendible Member) consists of two rolls of preformed, springy, metal sheet material (i.e. stainless steel or beryllium copper) that is stored flat on two rollers but curls longitudinally when the rollers are activated and the material unravels. The two curls, one inside the other for strength, then form an extendable, hollow rod which deploys the attached

flexible array. The system is applicable only to light weight panels to a limited extension (approximately 8 m). Major contributors to weight besides the BI-STEM material itself are the activator motor, gears, the rollers and the array's storage container.

Astromast is a heavier, single, extendable tower consisting of a network of open-air trusses that is motor driven to deploy the flexible blanket. Weight components include mast, motor, stowage container and related support hardware.

DSCS III is a representative of the latch and spring deployment scheme routinely used for conventional, smaller, rigid arrays. Typically, such systems are not light. Specifically, DSCS III involves approximately 11.0 kg. of hardware to deploy a 1.0 Kw. array. An advantage is that a folded, rigid array requires no stowage container during launch. Compared to the array power of DSCS III, the panels in this study range from 0.3 to 5.0 kW. Since the high end of this range is not achievable using DSCS III type deployment, arrays only to approximately 2.5 kW. are considered. To accommodate these different sizes, a scaling formula is used to extrapolate weight and power data from the original DSCS 1.0 kW. design.

### RESULTS AND DISCUSSION

Results of the comparison are shown in Figure 11. For simplicity, only BOL/LEO data is presented. Here the four uppermost curves detail the performance of the four different cell blankets deployed by inflation. Of special importance is the third curve from the top, designated by circles, demonstrating thin Si behavior. It is this curve that is most directly comparable to the other deployment methods plotted since they too used identical or near identical Si arrays. Clearly the system involving deployment by inflation is superior. For example, the specific power for the smallest ITSAT array, 308 Watts, is 290% higher than DSCS III and 28% higher than BI-STEM. At 1.232 kW, these figures increase to 347% and 49%. At 4.929 kW., ITSAT specific power is 68% greater than the same panel that is astromast deployed.

Of special note are the state of the art specific powers for flexible and rigid panels represented by the dashed horizontal lines at approximately 55 and 35 W/kg, respectively. BI-STEM and astromast systems, employing the optimized cells and flexible blankets of this study are clearly superior. However, these in turn are overshadowed in performance by the same cells and blanket design deployed by inflation. Specifically at 1.232 kW., ITSAT performance is 404% above the rigid panel level and 221% higher than that for flexible systems.

Compared to thin Si, however, the performance of the same inflation deployed blankets, this time populated with C/GaAs and CIS cells, is even better. Again for a 1.232 kW. panel for example, C/GaAs exhibits 523% and 296% increases over the dashed lines representing rigid and flexible specific powers. CIS figures are slightly less.

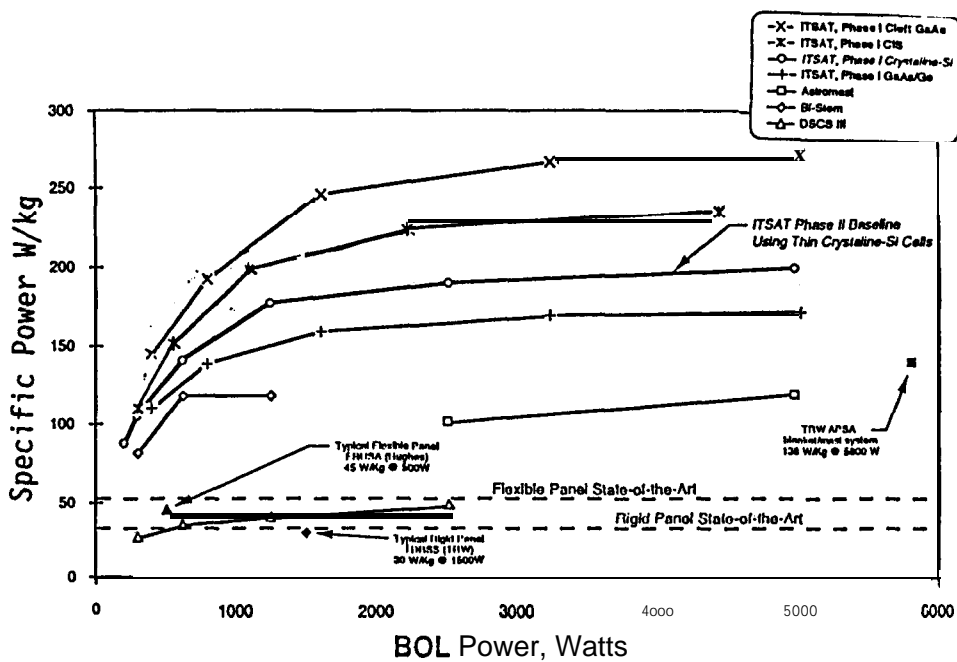

Figure 11. BOL/GEO - Deployment Comparison

#### CONCLUSIONS

This comparison study demonstrates that significantly lighter weight photovoltaic power systems are possible by incorporating into a single system design the most advantageous cell, blanket and deployment features.

Results demonstrate thin Si panels deployed by inflation outperform similar panels deployed by BI-STEM, astromast and DSCS-like methods. In turn ITSAT deployed blankets using solar cells that are still under development show promise in outperforming Si and GaAs/Ge panels.

In the 1.2 kW. range, using C/GaAs, five-fold and three-fold increases in specific power are achievable compared to standard rigid and flexible panels conventionally deployed. Although the present performance of CIS cells is slightly less, anticipated improvements in efficiency, size and possible monolithic interconnection may increase power and reduce weight and costs to eliminate this difference. The design of the system described in this study is adaptable enough to accommodate such new developments as they occur.

#### ACKNOWLEDGEMENTS

The authors are indebted to the following for data and thoughtful discussions: Alec Garcia and Pat Rahilly (The Aerospace Corporation), Dr. Bruce Anspaugh, Dr. Carol Lewis and Paul Stella (JPL), Dr. Richard Kurland (TRW), Dr. John Fan (Kopin Corp.) Dr. Vijay Kapur (ISET, Inc.) and Geoff Marks (Astro Aerospace Corp.).

This paper is the result of work performed by L'Garde, Inc. and its subcontractor SUM Associates under an Air Force contract managed by Phillips Laboratory. The program funded by DARPA, is under the direction of Lt. Col. Lee Demitry.

#### REFERENCES

- [1] P.M. Stella and R.M. Kurland, "Developmental Testing of the Advanced Photovoltaic Solar Array," Proc. 26th Intersociety Energy Conversion Engineering Conference, 1991, Boston, Massachusetts, pp. 269-274.
- [2] P.M. Stella and R.M. Kurland, "Operational Considerations of the Advanced Photovoltaic Solar Array," Proc. 27th Intersociety Energy Conversion Engineering Conference, 1992, San Diego, California, pp. 6.29-6.34.
- [3] W. Derbes, K. Guidanean, P.K. Malone, A. Palisoc, G. Veal, G. J. Vendura Jr., "Inflatable Torus Solar Array Technology Program, Phase I," Final Report, DARPA F29601-90-C-006, December 1991.
- [4] P. K. Malone, F. J. Jankowski, G. T. Williams and G. J. Vendura Jr., "Developing an Inflatable Solar Array," to be published.
- [5] V. K. Kapur and B. M. Basol, "Key Issues and Cost Estimates for the Fabrication of  $\text{CuInSe}_2$  (CIS) PV Modules by the Two-Stage Process," Proc. 21st IEEE Photovoltaic Specialists Conf., Kissimmee, Florida, 1990, pp. 546-549.
- [6] R. W. McLelland, J. C. C. Fan, R. P. Gale and B. D. Dingle, "High Efficiency Thin-Film GaAs Bifacial Solar Cells," Proc. 21st IEEE Photovoltaic Specialists Conf., Kissimmee, Florida, pp. 145-147.