

## SIGNIFICANCE OF THE INFLATABLE ANTENNA EXPERIMENT TECHNOLOGY

R. E. Freeland

Jet Propulsion Laboratory  
California Institute of Technology  
4800 Oak Grove Drive  
Pasadena, CA 91109-8099  
G. R. Veal, Member AIAA  
L'Garde, Inc.  
15181 Woodlawn Avenue  
Tustin, CA 92780-6487

### ABSTRACT

The IN-STEP Inflatable Antenna Experiment (IAE) was intended to demonstrate high payoff technology for large, inflatable space antenna structures, in a realistic operational environment. The experiment was based on the L'Garde, Inc. concept for a large, offset, parabolic reflector antenna and their associated technology data base at the time of initiation of the experiment in the early 1990's. The level of technology maturity at L'Garde, Inc. for their new antenna concept was commensurate with extensive space flight experience with small space deployable decoy-type structures and the capability for producing large flight prototype structural components such as reflector structures, strut and torus structures and lenticular structures. Since the IAE was the **first** large, high precision, multiple-structural element, inflatable/deployable space structure on orbit, a number of totally new technologies were demonstrated and evaluated. The new and unique technologies associated with this experiment include mechanical packaging techniques for membrane reflectors and rigidizable type support structures; handling, processing and assembly of thin membrane materials; ascent venting techniques for lenticular and strut/torus type structures; deployment control techniques for both reflector and support structures; and, the design and manufacturing of large, high precision, doubly curved, thin membrane reflector structures. **Due** to the lack of meaningful hardware demonstrations to establish the maturity of these technologies, prior to IAE, there was no serious interest by the Antenna User Community. The advent of the experiment seems to have changed this.

---

Copyright © 1998 by the American Institute of Aeronautics and Astronautics, Inc. All rights reserved.

### INTRODUCTION

The objective of the IAE was to demonstrate a level of technology maturity for large, inflatable deployable, space antenna structures for the user community based on the technology data base at L'Garde, Inc. at the time of initiation of the **experiment**<sup>1,2,3,4,5,6,7</sup>. At the time the experiment hardware was developed, there was a variation of the maturity level of the different critical technologies. However, it was felt that the lowest level of technology maturity was still consistent with the experiment basic criteria for high technology payoff, low cost and moderate risk. The specific critical technologies that had not **benefitted** from full scale hardware demonstrations, prior to the experiment included ascent venting, deployment control and mechanical packaging techniques for very large inflatable structures. This paper describes the technical approach used for each of the critical technologies, discusses the adequacy of the technology prior to and/or on orbit and the implication of experiment results on future technology development and application.

### PACKAGING TECHNIQUES FOR REFLECTOR AND SUPPORT STRUCTURE

The mechanical packaging techniques used for the IAE were based on a combination of recent experience at L'Garde, Inc. with a large number of small inflatable structures and new techniques tailored for the unique geometry of the experiment hardware'.

The **first** major decision on packaging techniques was to separate the three strut structures from the cavity that contained the reflector structure. This approach was used to eliminate physical interaction between the struts and torus/reflector structure during deployment, so that

separate control techniques could be used for each element of the support structure.

The highest mechanical packaging efficiency for the struts results from folding them in a "z" configuration with a separate container for each structure, referred to as "pods". This arrangement allows the struts to be pulled from their pods by the inertial forces from the reflector structure without interaction between them or the torus structure during the deployment.

The folding technique used for the reflector structure, which consists of the lenticular structure and the torus, was driven by the folding pattern of the torus structure. In order to interface the ejection plate with the most durable inflatable structure, the torus, the three segments of the torus, located between the joints with the struts, were folded into short/wide-pedestal type packages and placed parallel to each other on the ejection plate. The center part of the lenticular structure, which was not constrained by the torus at its outer perimeter, was folded into a "z" pattern and then located on top of the stowed torus structure. This packaging technique resulted in a near rectangular configuration that fit into the rectangular canister structure, Figure 1. However, since the canister

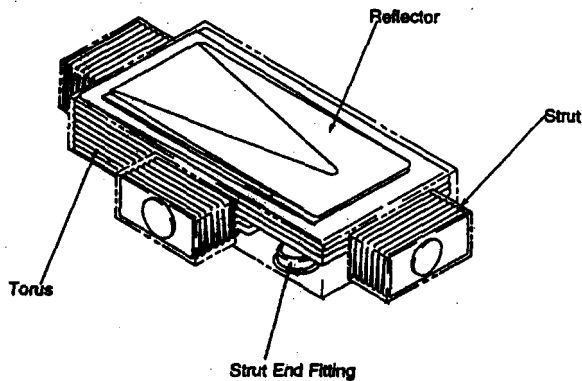

Figure 1. Packaging Configuration

shape was rectangular, and the final stowed configuration of the reflector structure was not exactly rectangular, dunnage was used to fill the voids. The dunnage was made from low-density honeycomb and its purpose was to prevent movement of the stowed reflector structure during the boost phase of the flight. Significant movement might have affected the planned orbital deployment sequence. These packaging techniques were based on the assumption that the amount of residual gas

in the stowed structure would have minimal impact on the planned deployment sequence. Based on the actual orbital performance, the combination of such packaging techniques, along with the appropriate control deployment devices, now under development at L'Garde, Inc., is expected to result in a highly controlled deployment sequence.

#### HANDLING, PROCESSING AND ASSEMBLY OF MEMBRANE MATERIALS

The reflector structure consisted of 62 **aluminized** Mylar gores that were 7 microns thick. Their geometric shape was based on an analytical process that utilized special computer codes. The membrane material is stored on rolls that are one meter wide. The surfaces of the tables and fixturing which were used to support the delicate membrane material must be very smooth and free of sharp obstacles. The cutting of the gores is done by a computer controlled laser machine. The membrane material is fed from its storage roll onto a table that supports the mobile-cutting tool. The gore shaped segments are then cut from the flat film. The gores are folded/transported/assembled by hand. The assembly process consists of placing the edges of two gores precisely against each other while being supported by curved tooling. At that time a tape doubler is placed over the two adjoining gore edges and bonded to them. During this process the gore material is supported by tables adjacent to the tooling. The placement of the membrane on the tooling and its support during the bonding operation is all done by hand. The assembled portion of the reflector is then folded into bundles for ease of its movement away from the assembly area.

Handling of the completed **14-meter-diameter reflector** membrane structure is accomplished in a number of ways. The structure is transported by folding it into a bundle which can be placed in a container. Evaluation of the reflective-surface precision and the operations involving its assembly with the canopy structure both require that it be unfolded into a planar configuration and tensioned around its perimeter. To accomplish this handling operation, a number of people were stationed around the perimeter of the membrane to apply very light loading at discrete points for purposes of (a) stretching the membrane so it can be mounted on a fixture, Figure 2, (b) positioning it for assembly with its canopy and (c) folding it after its attachment to the canopy. These procedures worked well for the **14-meter** diameter IAE reflector. It is estimated that these same procedures and processes will



Figure 2. Mounting Membrane on Test Fixture

accommodate the manufacture of reflectors up to “on the order of” 25 meters in diameter. Beyond that point, new and possibly semi-automated techniques will probably be required.

#### ANTENNA STRUCTURE ASSEMBLY

The techniques and approaches used for the assembly of inflatable deployable structures is dependent on a number of variables that include the materials characteristics, the size, mass, thickness and shape of the structural elements, the number of parts in the assembly, and the alignment tolerance. One of the most significant challenges for this type of structure is the assembly of large area, ultra-thin membrane structures such as the reflector and canopy structure for a large reflector antenna, such as the IAE.

#### LENTICULAR STRUCTURE

The lenticular structure consists of the reflector and canopy structures which are interfaced by means of a thin flexible torodial ring. Assembly begins with the mounting of the reflector structure on a “ring type” fixture that supports it at its outer diameter with a flange. It is aligned on the fixture so that the desired annular bonding area is directly over the top flange of the fixture. At this time, a differential pressure is applied across the reflector structure for purposes of removing all the wrinkles in the membrane in the area to be bonded. Next the flexible torodial rim structure is placed over the flange supported area of the reflector membrane and bonded to it. The canopy structure is then placed over the reflector structure, which is still mounted on its fixture, such that the pre-determined bonding area on the canopy is

mounted directly on top of the flexible rim structure. At this point the canopy is bonded directly to the top surface of the flexible rim. The interface of the lenticular with the torus is this flexible rim, which has 260 small holes at its edge to accept flexible ties from the torus structure.

#### LENTICULAR/TORUS STRUCTURES

The first step in the assembly of the torus to the lenticular is to establish a reference plane for the torus that represents a zero “g” loading configuration. The reason for this is that the lenticular is attached to the torus along this plane with 260 flexible adjustable ties. The zero “g” plane is established by submerging the torus in a large trough in a neutrally buoyant condition. When the unstressed configuration is achieved, a true plan is marked on the interior of the torus. Attachment hardware is then bonded to the torus structure. Assembly was achieved when the attachment hardware on each of the two structures was connected while they were in an uninflated configuration. Once the assembly was complete, both structures were inflated and each of the 260 tie points was adjusted to achieve the required radial loading to the lenticular structure.

#### TORUS/STRUTS/CANISTER STRUCTURE

The attachment of the struts to the torus was relatively simple in that a rigid adapter ring was used to interface the strut end fitting to a fitting that was bonded on the torus. Attachment of the struts to their pods which were part of the canister structure, involved attachment of the strut end fittings to their “register” on their pods.

#### ASCENT VENTING

The ascent venting issues associated with these types of space structure were accounted for in the design of the IAE hardware. However, due to the lack of space flight experience with this specific type and size of inflatable space structure, the effectiveness of the techniques used was not really adequate. Increasing the effectiveness of IAE ascent venting technology, and/or the development of new techniques will be used for the next flight of this type of inflatable structure.

#### TORUS AND STRUT STRUCTURE

The basic approach for ascent venting of the basic IAE support structure was to use bleeder cloth 0.25mm x

10cm along the full length of the struts and torus. This cloth was attached to the end fittings that interfaced the struts with the torus and the struts to their pods. Simulation of the launch environment in the vacuum chamber using full-scale prototype hardware indicated that the gas flow path in the struts and torus was not nearly sufficient to bring the residual air down to the point required prior to orbital deployment. The bleed cloth was then replaced with flexible lanyards whose diameter was considerably larger than the thickness of the bleed cloth. Further simulations in the vacuum chamber using full-scale strut structures indicated that three lanyards were needed for each strut and the torus. The flight results showed improvement over the bleeder cloth approach, as evaluated in the chamber, but not enough to enable the deployment control desired. It is believed that the very high mechanical packaging associated with the struts in their individual pods resulted in high enough loading of the membrane against the lanyards to minimize the gas flow around the lanyards. Additionally, it appears that there was enough residual gas in the MLI blankets, even though they were vented, to contribute to the deployment anomaly. A longer time in orbit prior to deployment would have significantly contributed to less residual gas in the stowed support structure and the lenticular structure.

### LENTICULAR STRUCTURE

The basic approach used for venting of the lenticular structure was to incorporate several dozen, 1mm diameter holes around the edge of the reflector structure. This approach appeared to be very simple and for a one-orbit experiment, the inflation gas loss would be trivial. However, on orbit there was still sufficient residual gas to cause “pillowing” of the entire lenticular structure as soon as its launch container was opened. This did not appear to have a detrimental affect on the deployment, but was not desired. It is believed that the compact packaging of the lenticular structure resulted in blockage of the vent holes from other areas of the membrane structure. This suggests that some type of large orifice valves, that could be closed prior to deployment, may provide a more effective gas flow path. Another option would be the “vacuum pack” used in the Echo Balloon Series<sup>9</sup>.

### DEPLOYMENT CONTROL

The basic deployment scheme for IAE was based on ejecting the stowed reflector structure, as a package, away

from its launch container prior to initiation of its own deployment<sup>11</sup>. This way the inertially-loaded reflector structure would essentially “pull” the struts out of their launch containers in a near uniform manner. When the struts were stretched to about 80% of their deployed length, a gas flow path would be developed and at that time inflation gas was to be introduced to all three struts at their intersection with the canister structure. While the struts were being pulled from their pods, a low rate of deployment of the lenticular structure would be initiated from the release of strain energy from the inflatable materials and a small amount of residual gas in both the torus and lenticular structure. The plan was that when the struts were nearly completely deployed, inflation gas would be introduced to the already partially deployed reflector structure in order to complete its deployment, Figure 3.

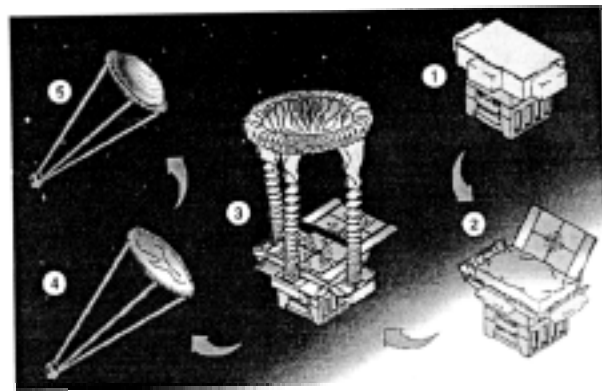

Figure 3 Planned Deployment Sequence

On orbit the magnitude of residual gas and the strain energy in the stowed structure was significantly more than anticipated. As a consequence, the planned deployment sequence did not materialize. Instead, the reflector structure deployed prematurely so that its planned ejection away from the canister did not take place. By the time the struts migrated from their pods as a consequence of residual gas and material strain energy, the reflector structure was over half deployed. However, due to the robust nature of this type of space structure, the torus and two of the struts completed deployment at about the same time and complete deployment of the third strut followed within a minute or two, Figure 4.

The results of the IAE strongly suggest that to achieve precise control of large inflatable structural elements, deployment control devices are required<sup>12,13,14</sup>. Such devices would be integrated directly into support structures, such as struts and toruses. A number of



Figure 4a.

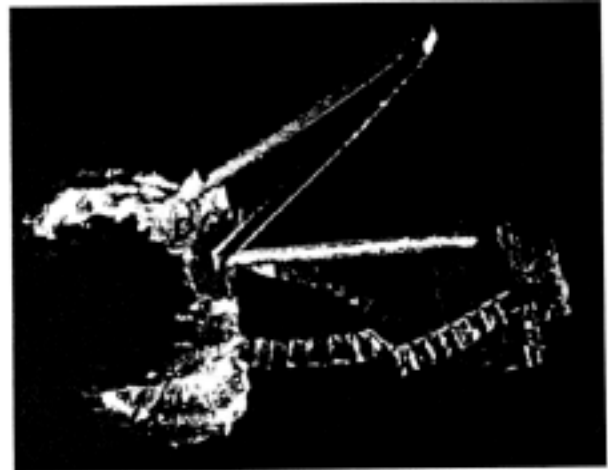

Figure 4b.

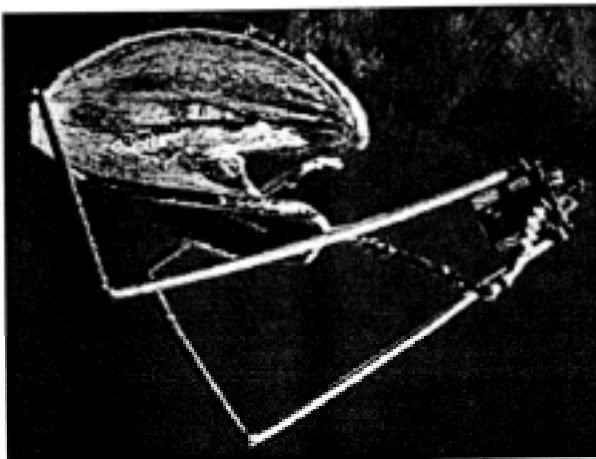

Figure 4c

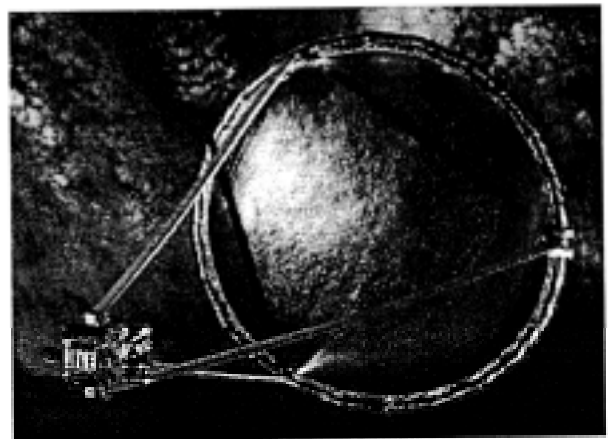

Figure 4d.

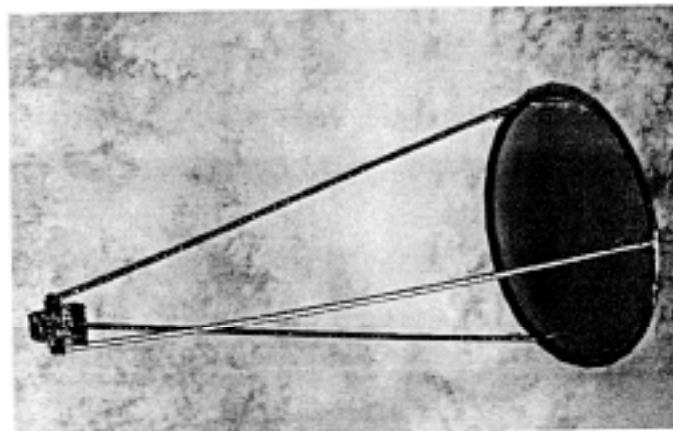

Figure 4e.

Figure 4. Actual Orbital Deployment Sequence

different types of control devices concepts have already been developed. A very promising approach would be to stow the support structure elements around a mandrel so that its rate of deployment could be controlled by adjusting the gap that the flexible material passes through. Deployment control of the lenticular type structures is also required to prevent "billowing" of the membrane structure prior to complete deployment of its support structure. Techniques to consider might include (a) ascent venting with mechanical valves, (b) vacuum packing prior to launch and (c) a restraint system for the stowed reflector structure that releases to enable its deployment in the appropriate time frame.

### HIGH PRECISION MEMBRANE REFLECTURE STRUCTURES

The surface precision of the inflatable deployable membrane reflector structure is a function of many variables which include (a) the geometry of the flat gores that are assembled to produce the reflector, (b) the properties of the materials used for the gores, (c) the cutting of the gores from the as manufactured materials, (d) the handling of the gores, (e) the assembly of the gores, and (f) the boundary condition of support for the reflector structure after integration with the complete antenna.

The procedures used for the IAE started with the selection of material which was 7-micron-thick aluminized Mylar. This material was available, in the thickness needed and had a low enough modulus to enable the required handling, processing and the assembly of the reflector. The determination of the gore shapes is done analytically. A L'Garde, Inc. computer code called FLATE solves the inverse problem of starting with the desired orbital shape, desired operating membrane stress and materials properties and calculates the unstrained flat gore shapes. The next step was to use the gore shape data as input to another L'Garde, Inc. Code called FAIM. This code accounts for all of the important manufacturing and assembly tolerances and then determines the reflector surface precision that can be expected for a given level of materials manufacturing and processing standards. This interactive analytical process is used until the projected surface precision is consistent with the design requirements.

The next step was the cutting of the gores, which was done with a computer controlled laser cutter. The required geometric precision of the finished gores was achieved to within 200 microns. The gores were then

folded, transported and aligned for assembly by hand. The gores were assembled, two at a time over curved tooling that represented the final reflector shape. The edges of the two gores were then butted together on the tooling so they could be joined together by the bonding of a tape doubler over both edges of the gores. As the gores were assembled, the completed part of the reflector structure was folded by hand into a long narrow bundle.

When the assembly of the reflector was complete, the determination of its precision was done by placing the reflector structure on a ring-shaped fixture the same diameter as the structure. It was then stretched and attached to the fixture along its outer edge. Then the same pressure differential, planned for orbit, was applied to the edge supported membrane. The surface precision was measured with photogrammetric techniques. The surface precision achieved was on the order of 2mm RMS, for the portion of the reflector about a meter away from its edge, Figure 5. This is the portion of the reflector that would normally be used for actual RF operation.



Figure 5. Reflector Membrane Mounted on Assembly Ring

The resulting surface precision of the as manufactured IAE reflector represented the level of technology available at L'Garde, Inc. during 1993<sup>1,2</sup>. Subsequent to that time, a number of advancements have been made to a number of the technologies affecting the reflector surface precision. For example, the current NASA sponsored technology program at L'Garde, Inc. is contributing to even further advancements. Consequently, future applications of this technology can expect much higher reflector precision than demonstrated by the IAE.

### CONCLUSIONS

The conclusions address how well the critical technologies demonstrated on orbit met the objectives of

the experiment and the needs of **future** experiments and applications of this technology.

The deployment control of each major structural element, including the canopy, is required to maintain high reliability. The actual orbital deployment was complete and successful due to the robust nature of inflatable deployable structures. The need for major improvement of ascent venting techniques was obvious and is currently being addressed. The low cost of these new types of space structure was demonstrated by building a large reflector structure for on the order of one million dollars. The outstanding mechanical packaging efficiency was demonstrated by stowing an antenna structure the size of the STS into a container the size of an **office** desk. The high surface precision of the membrane reflector structure validated procedures for the design, materials processing, and assembly for this type of structure. Since this reflector was the **first** of its type, modifications and/or refinements of the processes are expected to result in much-higher precision reflectors. The successful development of this very large inflatable antenna structure validated the processes, handling and procedures used for manufacturing inflatable support structures and membrane reflector and canopy structures. The technology used for the experiment, validated by the experiment and the resulting requirements for the future development of technology represent the new technical data base for this new class of space structures.

#### ACKNOWLEDGMENTS

The research described in this paper was carried out at the Jet Propulsion Laboratory, California Institute of Technology under a contract with the National Aeronautics and Space Administration and at the Goddard Space Flight Center. Development of the experiment flight hardware, evaluation of the flight data and the specific technical recommendations for continued technology development was done by **L'Garde**, Inc. under contract to JPL.

#### REFERENCES

1. Freeland, R. E. and Bilyeu, G., 'IN-STEP Inflatable Antenna Experiment,' IAF Paper 92-0301, presented at the 43<sup>rd</sup> Congress of the International Astronautical Federation, Washington, D.C., Aug. 28-Sept. 5, 1992.
2. Freeland, R. E. and Bilyeu, G., "IN-STEP Inflatable Antenna Experiment," *Acta Astronautica* Vol. 30, pp. 29-40, 1993.
3. Satter, **Celeste** M. and Freeland, Robert E., "Inflatable Structures Technology Applications and Requirements," AIAA Paper 95-3737, presented at the Space Programs and Technical Conference, Huntsville, AL, September 26-28, 1995.
4. Freeland, R. E., Bilyeu, **G.D.**, and Veal, G. R., "Development of Flight Hardware for a Large, Inflatable-Deployable Antenna Experiment," IAF Paper 95-1, 5.0, 1, presented at the 46<sup>th</sup> Congress of the International Astronautical Federation, Oslo, Norway, October 2-6, 1995.
5. Freeland, R. E., Bilyeu, **G. D.**, and Veal, G. R., "Development of Flight Hardware for a Large, Inflatable-Deployable Antenna Experiment," *Acta Astronautica*, Vol. 38, Nos. 4-8, pp. 25 1-260, 1996.
6. Thomas, M.; Veal, **G.**, "Highly Accurate Inflatable Reflectors, Report AFRPL TR 84-023, Prepared for the Air Force Rocket Propulsion Laboratory, dated May 1984.
7. Thomas, **M.**, Veal, **G.**, "Scaling Characteristics of Inflatable Paraboloid Concentrators", Presented at the Second **ASME-JSES-JSME** International Solar Energy Conference, **Reno**, Nevada, March 17-22, 1991.
8. Veal, **G.**, and Freeland, R., "IN-STEP Inflatable Antenna Description," AIAA Paper 95-3739, presented at the Space Programs and Technologies Conference, Huntsville, AL, Sept. 26-28, 1995.
9. Hanson, James, **R.**, "The Big Balloon," *Aerospace Magazine*, pp. 70-77, April/May 1994.
10. Freeland, R. E., Bilyeu, **G.**, and Veal, G. R., "Validation of a Unique Concept for a Low-Cost, Lightweight Space Deployable Antenna Structure," IAF Paper 93-1.1.204, presented at the 44<sup>th</sup> Congress of the International Astronautical Federation, **Graz**, Austria, Oct. 16, 1993.
11. **Freeland**, R. E. Bilyeu, G., and Veal, G. R., "Validation of a Unique Concept for a Low-Cost,

Lightweight Space Deployable Antenna Structure,” *Acta Astronautica*, Vol. 35, No.9-11, pp. 565-572, 1995.

12. Freeland, Robert; Bard, Steven; Veal, Gordon; Bilyeu, Gayle; Cassapakis, Costa; Campbell, Thomas and Bailey, M. C., “Inflatable **Antenna** Technology With Preliminary Shuttle Experiment Results and Potential Applications,” presented at the 18<sup>th</sup> Annual Meeting and Symposium of the Antenna Measurement Techniques Association, September 30-October 3, 1996, Seattle, Washington.
13. Freeland, R. E. Bilyeu, G. D., and Veal, G. R., “Large Inflatable Deployable Antenna Flight Experiment Results,” IAF Paper 97-1.3.01, presented at the 48<sup>th</sup> Congress of the International Astronautical Federation, Turin, Italy, October 6-10, 1997.
14. “Preliminary Mission Report: Spartan 207/**Inflatable** Antenna Experiment Flown on STS-77”, Spartan Project, NASA-GSFC, Feb. 14, 1997.