

# Comparison of Measured and Modeled Performance of a Tensioned Membrane Waveguide Array Antenna

Glenn D. Hopkins<sup>1</sup>, Robin L. Cravey<sup>2</sup>, Dion T. Fralick<sup>2</sup>,  
David Lichodziejewski<sup>3</sup>, Fred Redell<sup>3</sup>, and M. C. Bailey<sup>4</sup>

<sup>1</sup>Georgia Tech Research Institute, Sensors and Electromagnetic Applications Laboratory, Atlanta, GA 30332-0852

<sup>2</sup>National Aeronautics and Space Administration, Langley Research Center  
Mail Stop 490, Hampton, VA 23681-2199

<sup>3</sup>L'Garde, Inc., 15181 Woodlawn Avenue, Tustin, CA 92780

<sup>4</sup>Research Triangle Institute, One Enterprise Pkwy, Hampton, VA, 23666-5845

*Abstract* — For a variety of applications, it is desirable to have very large space-based antennas. As the physical size increases, antennas constructed of conventional materials become too bulky and heavy to be practical for space applications. For this reason, there is interest in finding new methods of fabricating large antennas which exhibit significantly lighter weight than conventional antennas. The light-weight antenna configuration investigated herein is a slotted waveguide array antenna with an integral microstrip feed, constructed of a metalized membrane material. Detailed Finite Element Method (FEM) models of key components and the entire array have been developed. A prototype 104-element L-band array has been fabricated and tested. This paper presents a comparison of measured and modeled performance of the tensioned membrane waveguide array antenna.

## 1. INTRODUCTION

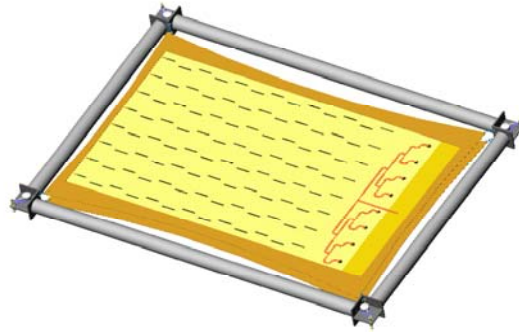
The work described in this paper is part of an ongoing research effort at NASA Langley Research Center (LaRC) to develop large, lightweight antennas for space-based earth remote sensing. NASA LaRC has been involved in developing concepts and materials for large, lightweight space antennas for several years [1, 2]. Antennas used for earth remote sensing applications often must be physically large in order to obtain the necessary resolution. Launching such large antennas into space becomes impractical unless one considers novel materials and lightweight configurations that can be packaged for launch and then deployed once in orbit. The membrane concept lends itself to compact packaging for launch, and can be tensioned on an inflatable, rigidizable support structure, which would deploy once in space. One major advantage of this planar configuration is that there is no need for fabricating a doubly curved surface (such as for a reflector antenna) from membrane material.

The slotted waveguide array antenna, first proposed by Bailey and Campbell [3] in 1998, is constructed of a metalized thin membrane material. In recent years, several component test articles of the array have been built and tested, culminating in the 104-element array with an integral feed network. The membrane array was designed, built, and tested by NASA LaRC, L'Garde, Inc, and the Georgia Tech Research Institute (GTRI). Results

from initial measurements were presented by Cravey, et al [4]. A description of the fabrication and deployment concept was presented by Lichodziejewski, et al [5]. This paper presents the complete FEM model of the array and a comparison of modeled and measured radiation patterns.

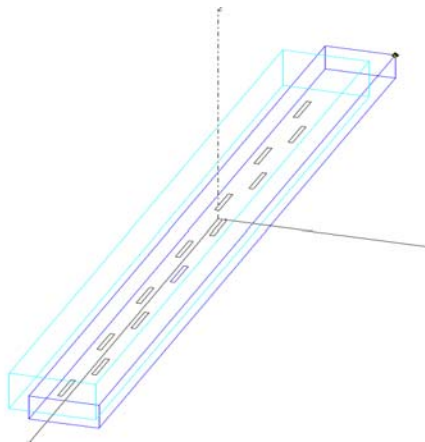
## 2. WAVEGUIDE ARRAY TEST ARTICLE

A CAD model of the 104-element array is shown in Figure 1. The array is constructed of 0.5 mil Kapton film metalized with 3000 angstroms of gold. The waveguides have a standard WR-650 cross section (6.5" x 3.25"). Each waveguide has 13 slots in the broad wall along its length. The antenna array is designed to operate at 1413 MHz. The overall dimensions of the array are approximately six by eight feet (1.8 by 2.4 m).

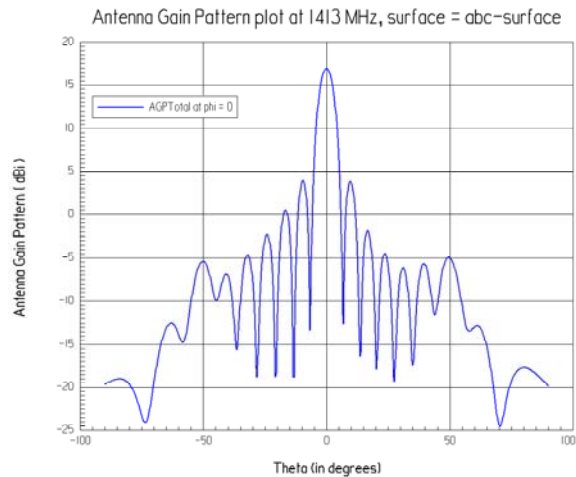


**Figure 1 – CAD model of the waveguide array**

The FEM computer model for a single waveguide is shown in Figure 2. The FEM analyses were completed using the High Frequency Structure Simulator, by Ansoft. It should also be noted that the metalized surfaces in all of the models were simulated as PEC. Figure 3 presents the modeled H-plane radiation pattern at the design frequency of 1413 MHz for the waveguide linear array. The pattern is well behaved with a centered mainbeam and symmetric sidelobes.



**Figure 2 - FEM model of one waveguide linear array**



The eight waveguides are fed by an 8:1 microstrip power divider network that is terminated in a Type N coaxial connector. The microstrip line is fabricated of the same metalized membrane material, supported by a strip of low loss, low dielectric Rohacell® foam material. The feed network foam is segmented to permit folding with the array membranes in the packaged array.

### 3. ANTENNA MEASUREMENTS



**Figure 4 – The membrane waveguide array antenna in GTRI’s near-field range. Pictured with the array are Leo Lichodziejewski (right) of L’Garde, Inc., the fabricator of the array, and Glenn Hopkins (left) of GTRI.**

The prototype array was fabricated by L’Garde, Inc. Radiation patterns were measured in GTRI’s planar near field antenna measurement facility, shown in Figure 4. The far field patterns calculated from the measured near field data demonstrated three features that were not anticipated. These included 1) a slight pointing error of the main beam in the azimuth pattern ( $-0.5^\circ$  at 1413 MHz); 2) asymmetry in the near-in sidelobes; and 3) low peak gain (approximately  $-4$  dB lower than expected). To investigate these traits, FEM models of the full array with its integrated beam former were developed.

The near field scans indicated that the beam squint was caused by a phase taper of  $-2.05$  degrees per radiator along the length of the waveguides. It was not believed that mechanical alignment in the range caused the beam pointing error. Tolerance analyses indicated that the range of waveguide broadwall dimensions that would result in such a phase error would only deviate from the desired 6.500 inches to either 6.4846 or

6.5097 inches (direction dependent). An equally likely candidate for the cause of the error is the effect of the membrane metalization thickness on the propagation constant of the waveguides. The Kapton membrane metalization was approximately 3000 Angstroms (0.0000003 m), primarily of gold. This thickness is equivalent to 0.0118 mils. The skin depth of gold at 1413 MHz was calculated to be 0.000002 meters, which is thicker than the metallization used. The metalization thickness is also considered a leading contributor to the lower than anticipated gain. Further analyses continue to investigate the effect of the metallization thickness on the array gain.

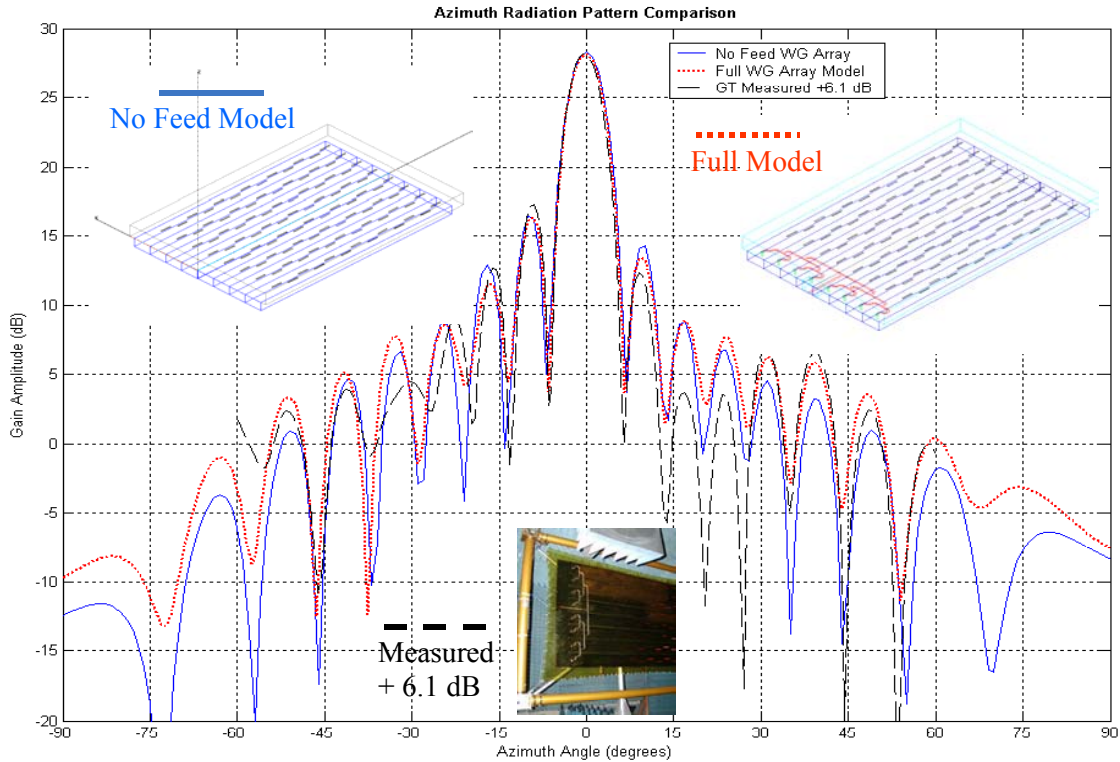
### 4. FEM ARRAY MODELS AND PATTERN COMPARISONS

To better understand the radiation pattern performance and assess potential undesirable radiation from the microstrip beam former, two computationally large FEM models were developed. Both models included eight waveguides and 104 slot radiators. The first did not include the beam former, and all eight waveguides were uniformly excited at the waveguide ports. The second modeled the entire array, including the beam former and the eight microstrip-to-waveguide transitions. Images of the two computer models are included with the H-plane radiation pattern comparison in Figure 5. The simulations were completed on one of GTRI’s 64-bit Sun computers and required approximately 6 Gbyte of RAM.

### 5. CONCLUSIONS

The array simulations did not exhibit any beam pointing, leading to the conclusion that that error was caused by the metalization thickness or fabrication tolerances of the

waveguides. The asymmetry of the first two sidelobes was observed in both models as well as the measured data. Additional analysis of the near fields indicates that the sidelobe asymmetry is likely caused by the mutual coupling between the radiators and the edge element effect of the finite array. The first and last columns of radiators are not in phase with the majority of the array. The cause of the lower than expected gain is still not verified, but it is likely a combination of higher than expected losses in the thin metalization and radiation from the feed network.



**Figure 5 – An overlay of H-plane far field radiation patterns from: the simulated array with no microstrip beam former (blue, solid), the simulated array with beam former (red,dotted), and measured data corrected in gain to match the simulated levels (black, dashed).**

## REFERENCES

- [1] R.F. Harrington and H.-J.C. Blume, "Determination of Electromagnetic Properties of Mesh Material Using Advanced Radiometer Techniques," *Proceedings of the Large Space Antenna Technology Symposium*, December 1984.
- [2] R.L. Cravey, H.-J.C. Blume, C.P. Hearn, M.J. Scherner, L.C. Schroeder, and R.F. Harrington, "Electromagnetic Losses in Metallized Thin Films for Inflatable Radiometer Applications," *Proceedings of the AIAA 1995 Space Programs and Technologies Conference*, September 26-28, 1995, Huntsville, AL, AIAA Paper 95-3741.
- [3] M.C. Bailey and T. G. Campbell.: "Inflatable Tensioned Membrane Waveguide Antenna Array for Space Applications", IUTAM-IASS Symposium on Deployable Structures, Cambridge, UK, September 6-9, 1998.
- [4] D.T. Fralick, R.L. Cravey, G.D. Hopkins, D. Lichodziejewski, and M.C. Bailey, "Performance Evaluation of a Membrane Waveguide Array Antenna," IEEE Aerospace Conference, March 8-15, 2003 Big Sky, Montana, Paper IEEE-AC 1148.
- [5] D. Lichodziejewski, R.L. Cravey, and G.D. Hopkins, "Inflatably Deployed Membrane Waveguide Array Antenna for Space," Proceedings of the 44th Structures, Structural Dynamics, and Materials Conference, Norfolk, Virginia, Apr. 7-10, 2003, Paper AIAA-2003-1649.