

VALIDATION OF A UNIQUE CONCEPT FOR A LOW-COST,
LIGHTWEIGHT SPACE-DEPLOYABLE ANTENNA STRUCTURE

R. E. Freeland*
Jet Propulsion Laboratory
California Institute of Technology
Pasadena, California

G. D. Bilyeu**
G. R. Veal†
L'Garde, Incorporated
Tustin, California

Abstract

Large space-deployable antennas are needed for a variety of applications that include mobile communications, radiometry, active microwave sensing, very-long-baseline interferometry, DoD space-based radar, and microspacecraft. Investigators in these fields identify the need for structures up to tens of meters in size for operation from 1 to 90 GHz, based on different aperture configurations. The selection criteria common to all of the users are low cost, light weight, high reliability, and good reflector surface precision. Fortunately, a unique class of space structures has recently emerged that offers great potential for satisfying these criteria. They are referred to as inflatable deployable structures. A good example of such a concept is under development at L'Garde, Inc.

Serious interest from the user community will depend on realistic demonstrations of the viability of the concept. This means that large, lightweight, low-cost structures need to be developed and used to demonstrate deployment reliability in realistic service environments. The technology data base for the

L'Garde inflatable concept will accommodate the development of reflector antenna structures up to 30 meters in diameter. Since the concept utilizes very low inflation pressure to maintain the required geometry on orbit, gravity-induced deflection of the structure precludes any meaningful ground-based demonstrations of functional performance. Therefore this concept has been selected for a NASA In-Space Technology Experiments Program (IN-STEP) space-based experiment.

The objectives of this experiment are to validate and characterize the mechanical functional performance of a **14-meter-diameter** inflatable deployable reflector antenna structure in the orbital operational environment. The experiment will be carried by the NASA Spartan spacecraft, which is launched, deployed, and recovered by the **STS**. The Spartan will provide mounting, attitude control, power and data recording for the antenna experiment.

The antenna concept development will benefit from both the experiment and supporting technology developments. Results of this experiment are expected to verify the feasibility of fabricating a large space structure for only a few million dollars, demonstrate the reliability of deployment, characterize the quality of the reflector surface, and correlate the analytical performance prediction models with actual measured characteristics. Technology developments in support of the experiment, to be conducted at NASA Langley Research Center and the University of Colorado, will include investigation of new and advanced flexible materials, as well as system studies to assess the

*Manager, IN-STEP Inflatable Antenna Experiment, Applied Mechanics Technologies Section

**Program Manager, Inflatable Antenna Experiment

†Experiment Principal Investigator

adequacy of this structural concept for specific classes of applications and for the development of analytical performance production tools. These combined results will be used to advance the technology of the concept with respect to improving surface precision and performance predictability and accommodating larger size structures with different configurations in different orbits.

1. Introduction

Large self-deployable, reflector antennas are needed for a large variety of space-based applications. These potential applications include (a) mobile communications,^{1,2,3,4} (b) earth observation radiometry,^{5,6,7,8,9,10,11,12} (c) active microwave sensing, (d) orbiting very-long-baseline interferometry (OVLBI),^{13,14,15,16,17} (e) space-based radar, and (f) microspacecraft.¹⁸ The antenna size and frequency ranges for these classes of applications are given by Figure 1.

However, the limited number of such applications at this time, in the large-size range, signifies that there are problems associated with actually using state-of-the-art space-deployable structures concepts. The problems result from very high hardware costs, concern about mechanical deployment reliability, and the high weight of many of the concepts. For example, a E-to-30 meter diameter mechanically deployable space antenna structure would cost on the order of several hundred million dollars. Additionally, mechanical concepts in this size range, have not actually demonstrated high deployment

<u>APPLICATION</u>	<u>APERTURE SIZE RANGE (m)</u>	<u>RF RANGE (GHz)</u>
MOBILE COMMUNICATIONS	10-20	1.5
MOBILE COMMUNICATIONS	4-6	20-30
EARTH OBSERVATION RADIOMETRY	20-40	1.4-60
ACTIVE MICROWAVE SENSING	0.4 x 2 & 4 x 16	1-94
OVLBI	20-25	0.3-90
DOD SPACE BASEDRADAR	20-30	1.5-2.5
MICROSPACECRAFT	0.5-3	6.5132

Fig. 1. Potential Antenna Applications

reliability in a realistic operational environment. These factors collectively tend to discourage applications of current large deployable structures technology. Therefore, it is not surprising to find that the user criteria for selecting specific concepts for any of the applications is essentially the same: low cost, low weight, high deployment reliability, and high aperture precision. It is not surprising to see that this selection criteria is absolutely consistent with the new NASA theme of cheaper, faster, and better technology. In fact, this criteria and philosophy would be an excellent basis for the selection for antenna structural concepts for technology development.

Once a specific antenna structural concept, with potential for meeting the stringent user criteria has been identified for application or technology development, the next major challenge is the validation of the concept to the satisfaction of that user community. Such validations, to be meaningful, will have to actually demonstrate that the concept mechanical capability satisfies the criteria. This means that (a) low-cost and lightweight hardware can only be verified by actually building large flight-quality hardware; (b) deployment reliability can only be demonstrated with large flight-type hardware in a realistic service environment; and (c) usable reflector surface precision will have to be demonstrated in a realistic service environment. Very often this means a space-flight experiment is absolutely essential for a meaningful validation.^{19,20,21,22}

Fortunately for the users, a unique concept has resulted from recent technology developments in the area of large inflatable deployable space structures. This new concept has tremendous potential for satisfying at least three of the antenna user community criteria, i.e., low cost, light weight, and high deployment reliability. The best example of this type of structure is the L'Garde, Inc., offset, parabolic, inflatable deployable, reflector antenna concept. The entire antenna structure is made from thin flexible membrane materials. This unique structure consists of (a) the reflector structure and an RF transparent canopy used to form a closed cavity so that inflation gases will put tension on the two membranes, (b) a multiple layer torus structure that supports the reflector/canopy assembly through a large number of attachment points around its perimeter, and (c) three multiple-layer struts that interface the torus with the feed support structure. Deployment is accomplished by introducing inflation gas sequentially to the stowed

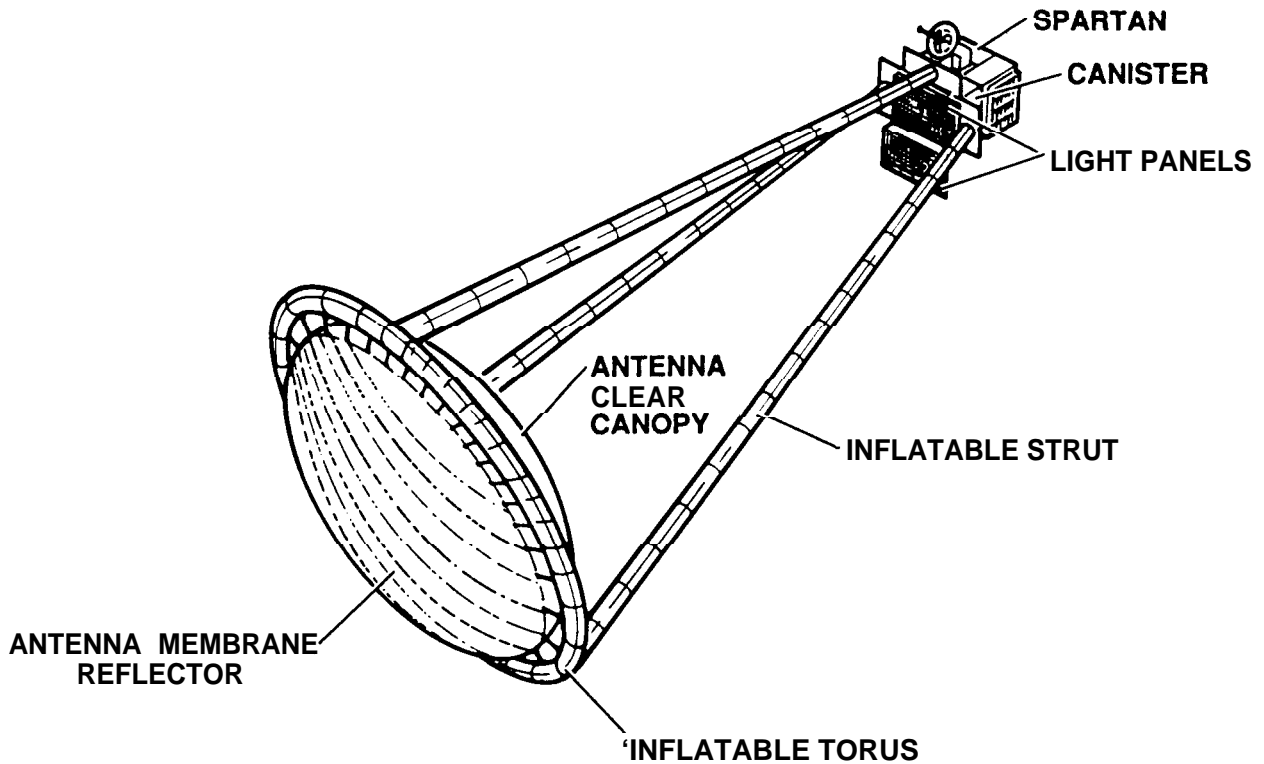

Fig. 2. Experimental Orbital Configuration

struts, torus, and reflector/canopy, respectively. The details of this structure are given by Ref. 25. This structure is cheap because it is constructed from only inexpensive membrane materials and does not utilize any high-precision mechanisms, complicated structures, exotic materials, or electromechanical devices. The structure is very light since the thickness of the reflector and canopy membrane is on the order of 6 to 8 microns and the thickness of the torus and struts is on the order of a few hundred microns. Deployment reliability is very high since the structural elements simply unfold from the stowed configuration as they are pressurized sequentially. Proper control of the inflation pressure results in a smooth expansion of the inflatable elements from stowed to fully deployed structural configuration. The deployment of the individual elements of the antenna is similar to the inflation of a life raft and the escape chute from an airliner.

The validation of this new type of space structure concept for the potential user community must be based on (a) developing structures close to the size required for actual applications, i.e., 15 to 30 meters, (b) flight-quality hardware, (c) demonstrating deployment reliability in a realistic service

environment, and (d) the actual measurement of usable reflector surface precision. Unfortunately, a ground-based hardware evaluation of functional performance for this concept is not meaningful because (a) the low stiffness of the partially deployed structure would allow gravity loading to completely distort the deployment characteristics, (b) the presence of an atmosphere would significantly change the inflation time and articulation characteristics of the reflector and canopy during deployment, and (c) orbital inflation pressures are so low that gravity-induced deflections would preclude measurement of the reflector surface. Consequently, a zero-gravity environment is absolutely essential for a realistic validation of this class of space structures.

As a consequence of the high-potential payoff of this concept for the user community and the need for zero gravity mechanical performance evaluation and demonstration, the L'Garde inflatable antenna concept has been selected by NASA for an In-Space Technology Experiments Program (IN-STEP) flight experiment,²³ Figure 2. The experiment is currently in the detail design phase of development. This paper discusses (a) antenna user selection criteria (b) an approach for validating large space antenna concepts,

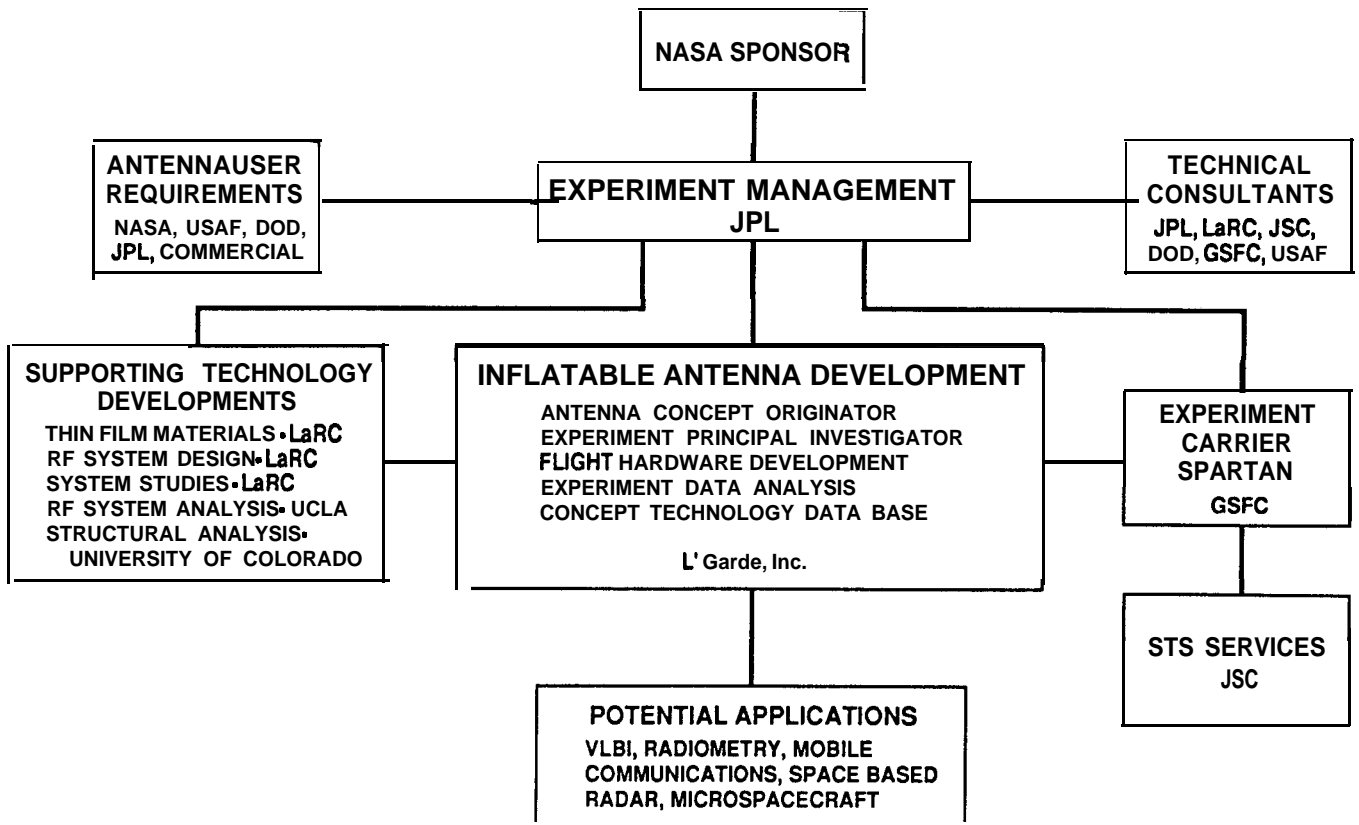

Fig. 3. Functional Organization

(c) a flight experiment that implements the validation approach^{24,25} for an inflatable antenna concept, and (d) supporting technology developments that help advance the maturity of this concept.

2. IN-STEP Inflatable Antenna Experiment

The NASA Office of Aeronautics and Space Technology (OAST) is currently sponsoring the In-Space Technology Experiments Program. It is specifically intended to sponsor low-cost, high-payoff technology payloads such as the inflatable antenna concept. IN-STEP sponsors experiments through proposal response to the NASA Announcement of Opportunity. Experiments selected for development are funded through the feasibility study (Phase A). Experiments selected for further development then proceed to preliminary design (Phase B) and detail design and flight hardware development (Phase C/D). The Inflatable Antenna Experiment was initiated in 1988 and advanced to Phase C/D in late 1992. The experiment is managed by JPL for NASA. The experiment hardware is under development at L'Garde, Inc., who is the innovator of this inflatable antenna concept and is the Principal Investigator and

industrial partner to JPL. The experiment project organization is based on (a) maintaining close contact with each user community, (b) utilizing recognized experts from different organizations as consultants, (c) working directly with organizations supporting the experiment, and (d) providing estimates of performance for specific applications. This successful working relationship is given by Figure 3. The experiment is currently manifested to fly on STS 78 in early 1996.

Experiment Objectives

The objectives of this IN-STEP experiment are intended to address the concerns of the user community and significantly reduce the risk of using this new type of space structure. Consequently, the specific objectives are to (a) validate the deployment of a 14-meter-diameter, inflatable deployable, offset parabolic reflector antenna structure in a zero-gravity environment, (b) measure the reflector surface precision, which is expected to be on the order of 1-mm rms, for several different sun angles and inflation pressures in a realistic thermal environment, and (c) investigate the structural damping characteristics of this unique type of space structure.

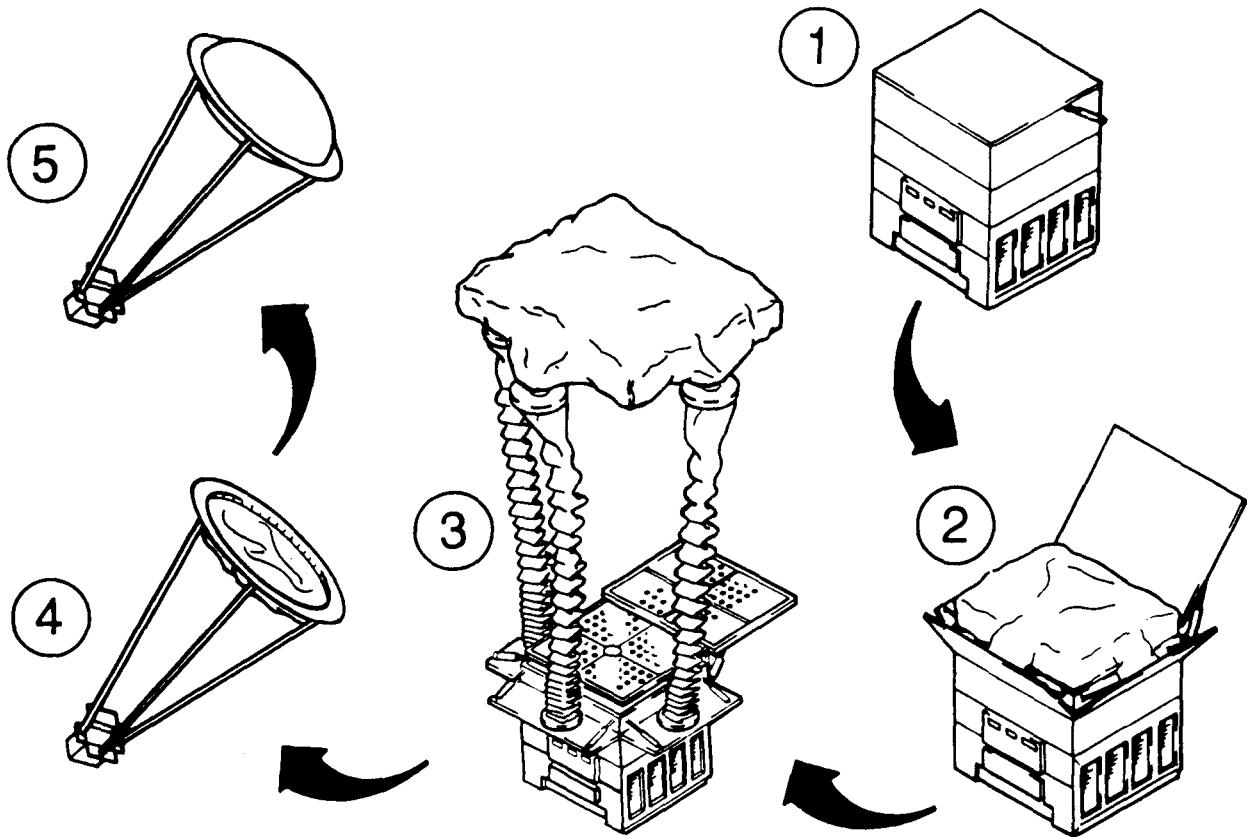

Fig. 4. Antenna Deployment Sequence

The reflector diameter of 14 meters was selected for a number of reasons: namely (a) it is consistent with the range of sizes for possibly early applications; (b) it is the largest size structure L'Garde can produce with their existing facilities and still minimize the experiment costs; (c) the experiment hardware will be made with the processing, materials, fabrication, and assembly techniques used for structures up to 30 meters so that the 14-meter mechanical performance can be extrapolated to structures that size; (d) it represents a reasonable extension of the existing g-meter diameter technology data base; and (e) a structure of at least this size needs to be built to show that big lightweight inflatable structures can be produced for only a few million dollars.

To be meaningful, the validation of deployment needs to address all of the events, which include (a) initial position and configuration of the stowed reflector structure after it is released from the canister, (b) the change of structural configuration associated with each of the four deployment sequences, and (c) the time required for inflation of each of the

sequences, Figure 4. Deployment starts when the stowed inflatable structure is ejected from the canister by a spring-loaded floor plate. Next the deployment of the struts is initiated by the strain energy resulting from stowing the inflatable members. Deployment is then completed by inflation of the struts. By this time, deployment of the torus has been initiated by release of its strain energy and completed by inflation. After this support structure has been completely deployed, the reflector and canopy are then inflated.

Surface precision measurements, to be useful for application purposes, need to be made (a) over the entire reflector surface, (b) at various sun angles for constant internal pressures, (c) at several different internal pressures for the same thermal environment, and (d) in a timely manner to minimize the effects on the changing thermal environment on measurements.

Experiment Description

The antenna experiment orbital system configuration is shown in Figure 2. The basic elements of the system include the (a) inflatable torus,

which is the support structure for the reflector, (b) the inflatable parabolic membrane reflector structure, (c) the inflatable struts, which have capability for supporting a feed or subreflector structure, but, for this experiment, terminate at the canister, (d) the canister, which interfaces the antenna experiment to the Spartan, supports the stowed antenna and other experiment equipment, incorporates deployable doors to access the antenna to the space environment, and provides mounting for the surface measurement system, (e) the instrumentation system that consists of high-resolution television cameras and a digital imaging radiometer, which are mounted in the canister, and (f) the Spartan, which is the carrier for the experiment and provides initiation commands to the experiment controller.

The most cost-effective approach to putting a structure of this type and size on orbit for this type of an experiment is to use the Spartan recoverable spacecraft as the experiment carrier, Figure 2. The Spartan is taken to orbit and returned to Earth by the Space Transportation System (STS). The Spartan, developed by the NASA Goddard Space Flight Center (GSFC) and successfully flown previously, will provide (a) a mounting platform for the antenna structure and experiment equipment, (b) power, (c) attitude control, (d) recording of the experiment data, and (e) a separation system for the ejection of the antenna structure subsequent to completion of the experiment. Accordingly, the Spartan Project Office will be the Mission Manager for the experiment.

The instrumentation system for the experiment consists of (a) high-resolution, wide-angle and narrow-angle television cameras to monitor deployment, (b) a digital imaging radiometer for measurement of the reflector surface precision, and (c) an engineering monitor for pressures, temperatures, sun angle and time reference. In addition to the experiment television cameras, high-resolution photography from the STS is expected to be available for monitoring the complete inflatable structure deployment sequence. This is essential since the experiment cameras will not be able to acquire the initial phases of deployment because of their close proximity to the stowed inflatable structure.

Orbital Scenario

The orbital functional scenario for the experiment starts with the Spartan being placed

overboard by the STS Remote Manipulator System (RMS). Once the orbiter has moved a safe distance away and the Spartan has been stabilized by its attitude control system, a start command, from the Spartan to the experiment controller initiates implementation of the experiment. Antenna deployment commences with the opening of the canister doors; the spring-loaded floor plate then pushes the stowed structure away from the canister. The inflation system then provides nitrogen gas to the stowed inflatable structure., The entire deployment sequence will take on the order of 5 minutes. Measurements of surface precision for several sun angles and reflector/canopy inflation pressures will be made during the first one or two orbits. Since the high drag of the reflector structure will cause separation of the Spartan from the orbiter, and only one orbit is required to implement the experiment, the antenna will be separated from the Spartan at the completion of the measurements. The Spartan with the experiment data will be recovered by the orbiter at the end of its standard mission.

Ground-Based Test Program

The ground-based test program addresses the development, evaluation, and verification of mechanisms, inflatable and canister structure, instrumentation systems, electronics subsystems, and the inflatable system. This ground-based test program will reduce the experiment risk through extensive demonstration of hardware functional performance that lends itself to meaningful ground-based evaluation. This test program is defined in detail by the Project Developmental Test Plan that was generated as a significant part of the experiment preliminary design. The major elements of this program include (a) canister mechanisms functional and structural testing, (b) full-scale inflatable structure packaging, (c) subscale reflector structure element deployment testing and surface accuracy measurement, (d) electronics functional testing, (e) inflation system functional testing, (f) surface measurement system functional testing and calibration, (g) reflector assembly and adjustment procedures refinement, and (h) environmental testing at the assembly and subsystem level, Figure 5.

3. Supporting Technology Developments

In addition to the flight experiment itself there are a number of supporting technologies under development at organizations other than JPL/L'Garde,

- MEMBRANE MATERIALS CHARACTERIZATION
- CANISTER DOOR DEPLOYMENT
- INFLATABLE STRUCTURE SUBSCALE STRUCTURES CHARACTERIZATION
 - ELECTRONIC SUBSYSTEM FUNCTIONAL AND ENVIRONMENTAL TESTING
 - SAMS* LIGHT PANEL FUNCTIONAL AND ENVIRONMENTAL TESTING
 - SAMS VIDEO CAMERA FUNCTIONAL AND CALIBRATION TESTING
 - INFLATABLE STRUCTURE PACKAGING AND DEPLOYMENT CHARACTERIZATION
 - DYNAMIC MEASUREMENT SYSTEM FUNCTIONAL TESTING
- DEPLOYMENT SURVEILLANCE VIDEO CAMERA FUNCTIONAL AND ENVIRONMENTAL TESTING
 - VCR CONTAINER STRUCTURAL INTEGRITY TESTING
 - INFLATION SYSTEM FUNCTIONAL AND ENVIRONMENTAL TESTING
- REFLECTOR STRUCTURE ASSEMBLY AND ADJUSTMENT PROCEDURES DEVELOPMENT
 - REFLECTOR STRUCTURE SURFACE ACCURACY MEASUREMENT
 - *SURFACE ACCURACY MEASUREMENT SUBSYSTEM

Fig. 5. Ground-Based Development Tests

Inc. These developments contribute significantly to the experiment and the inflatable antenna concept technology data base. The results of these contributions will (a) enhance the quality of the experiment flight hardware, (b) advance the technology of the basic concept for subsequent flight applications, and (c) help determine the applicability of the inflatable antenna concept for several specific applications. The organizations providing this extremely important contribution to the advancement of technology include: the NASA Langley Research Center (LaRC), the University of Colorado, and the University of California at Los Angeles (UCLA).

The NASA Materials Research Division at LaRC is addressing the identification, the mechanical characterization, and the investigation of improved thin film materials for the inflatable antenna concept. Improved membrane materials properties would be in the area of (a) uniform thickness, (b) uniform stiffness properties, and (c) radiation resistant thin film materials. The currently available commercial materials to be used for the experiment are more than adequate to accommodate the technical objectives of the experiment. However, for long-term applications requiring higher antenna reflector surface precision, and long-term structures dimensional stability, advanced thin film materials will definitely be required.

The NASA LaRC Antenna and Microwave Research Branch is developing antenna feed configuration designs for two classes of applications

for the inflatable antenna concept. These applications include earth observation radiometry for soil moisture and advanced space-based very long baseline interferometry (VLBI). An RF concept for a soil moisture and oceanographic radiometer based on using the inflatable reflector antenna has been developed and is illustrated by Figure 6 and discussed in Ref.5. The purpose of the study is to characterize the potential RF performance of this concept for these applications. The results of this study will be the input to the systems studies.

The NASA LaRC Advanced Space Concepts Division is developing candidate spacecraft system configuration designs for each of the two applications. The output of the RF configurations will be the basis of the system analysis. The purpose of these system studies is to establish the feasibility of using the inflatable antenna subsystem in conjunction with conventional spacecraft technology. The results of these studies will include (a) launch vehicle options, (b) satellite configuration, (c) performance/mass trade-off, (d) orbit analysis, (e) thermal and loads analysis, and (f) instrument subsystem.

The University of Colorado, College of Aerospace Engineering, Center of Space Construction, is developing analytical approaches for the accurate mechanical characterization of inflatable space structures. The purpose of the development is to determine how to use standard or modified/standard structural computer codes to accurately simulate the mechanical performance of this unique type of space

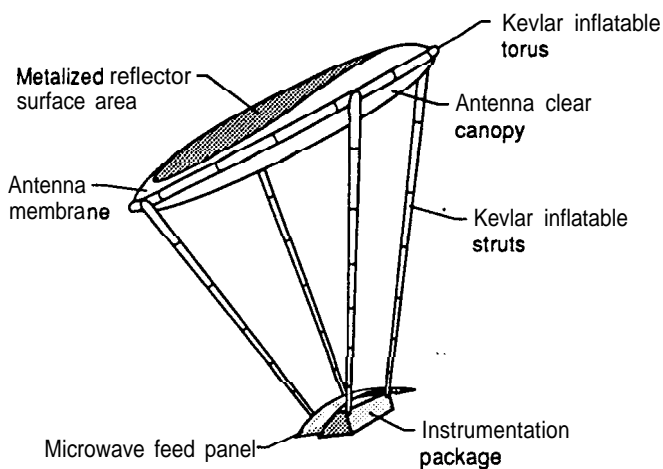

Fig. 6. Radiometer Using Inflatable Reflector Technology

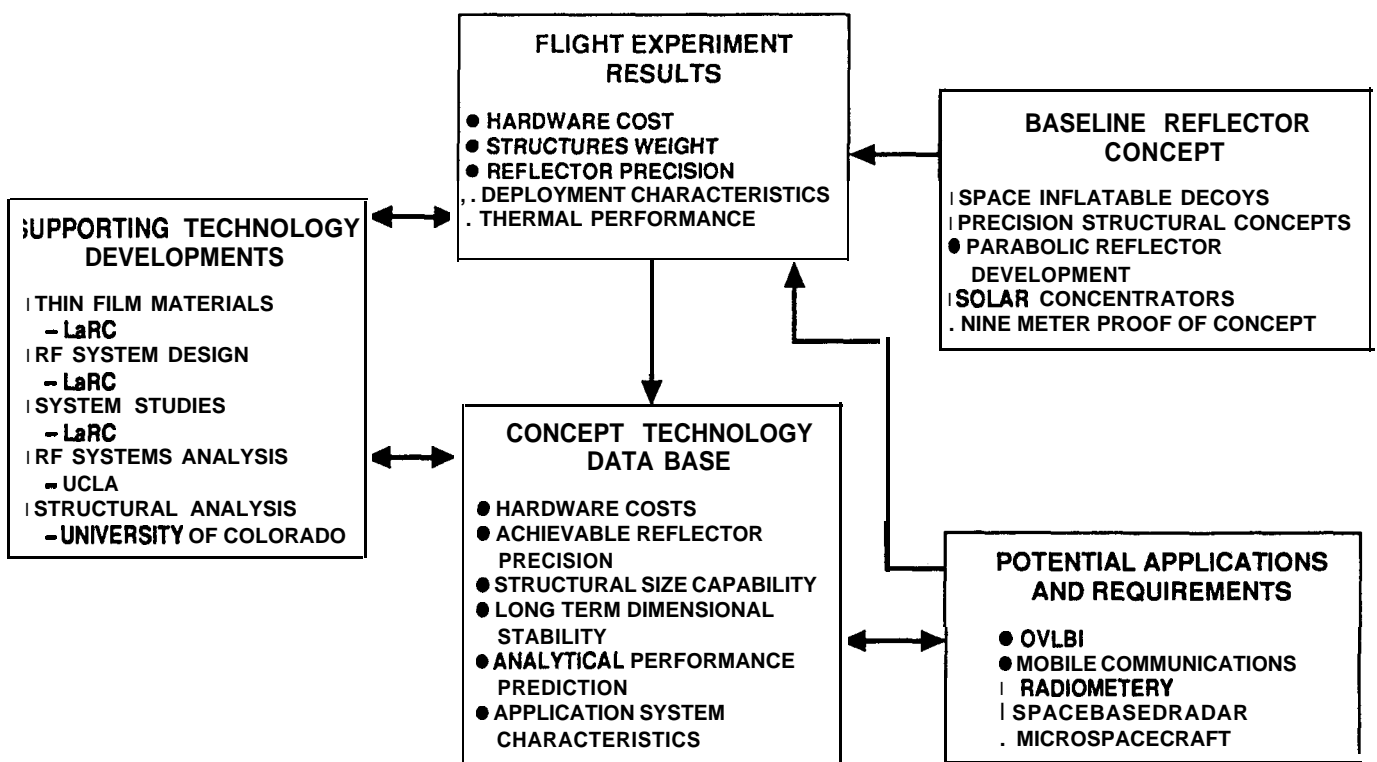

Fig. 7. Inflatable Antenna Concept Technology Development

structure. This research will be based on analysis, test of inflatable structures elements, test/analysis correlation and analytical model refinement.

A representative of the UCLA Department of Electrical Engineering is supporting the experiment by (a) membership on the antenna user advisory committee, (b) membership on the experiment design review boards, and (c) technical consulting on predicting and measuring antenna system performance.

4. Concept Technology Data Base

The integral of the results of the flight experiment and the supporting technologies is expected to significantly advance the technology data base for the inflatable antenna concept as a consequence of the following: (a) the orbital antenna performance will be validated and characterized for purposes of evaluating the specialized manufacturing processes and assembly techniques; (b) the technologies to be used for producing higher precision reflector structures will be advanced; (c) new materials for long-term dimensional stability will be **available** for application; (d) the technologies used for the analytical projections of antenna performance will be verified and enhanced; and (e) candidate system configurations for specific classes of application will be developed, Figure 7.

The baseline concept **mechanical** performance on orbit, which will be characterized and validated by the experiment, will be a **function** of the inflatable materials used, their processing assembly techniques, and the mechanical packaging configurations. Refinements and modifications of these processes and techniques along with the application of new and improved membrane materials will result in higher reflector surface precision, long-term dimensional stability, and support structures with greater stiffness. **Improved** analytical performance projection capability will facilitate using the experiment results and **ground-based** materials characterizations to accurately predict functional performance for applications utilizing larger structures, and different functional configurations and orbits. The adequacy of this unique concept for several specific applications will be determined by the results of the RF subsystem and spacecraft systems studies.

5. Conclusions

The results of the experiment are expected to significantly reduce the user risk associated with using large **space-deployable** antennas by demonstrating the **functional** performance of a concept that meets the criteria for low-cost, lightweight, and highly reliable space-deployable structures. The results of the experiment in conjunction with the supporting technologies

are expected to advance the concept technology data base to the point of accommodating applications in the size range of 14 to 30 meters in the late 1990s and 30 to 50 meters in the early 2000s. The technology resulting from these activities is made possible by the joint partnership between NASA and private industry.

Acknowledgments

The research described in this paper was carried out at the Jet Propulsion Laboratory, California Institute of Technology, under a contract with the National Aeronautics and Space Administration. Development of the flight experiment is being done by L'Garde, Inc., under contract to JPL.

The authors would like to acknowledge the following individuals for their contribution to the flight experiment. Because of the number of different elements associated with the experiment hardware development, concept data base advancement, and antenna applications issues, the success of this project to date is directly proportional to the outstanding support from: D. Carson, NASA GSFC Spartan Project **Office**, Mission Manager; M. Lewis, NASA JSC Payload Integration Manager; T. G. Campbell of NASA **LaRC** for RF system studies; R. A. Russell of NASA **LaRC** for system studies; D. Tenney of NASA **LaRC** for materials development; M. Mikulas of the University of Colorado for structural analysis; Y. Rahmat-Samii of the University of California at Los Angeles for project review and RF consulting; and A. Palisoc, M. Thomas, T. Dagget, and C. Cassapakis of L'Garde, Inc., for experiment development; A. B. Chmielewski of JPL for experiment administration; W. Gulizia, JPL Product Assurance Manager; L. Combes, JPL Safety Engineer.

References

1. Ciesluk, Jr., W. J., Gaffney, L. M., Hulkower, N. D., Klein, L., Krueger, P. E., Oliver, and P. A., Pomponi, R. A. "Survey of the Mobile Satellite Communications Industry," MTR 92B0000059, MITRE, Bedford, MA, Apr. 1992. (This document was prepared for authorized distribution. It has not been approved for public release.)
2. Ciesluk, Jr., W. J., Gaffney, L. M., Hulkower, N. D., Klein, L., Oliver, P. A., Pavloff, M. S., Pomponi, R. A., and Welch, W. A. "An Evaluation of Selected Mobile Satellite Communications Systems and Their Environment," MTR 92B0000060, MITRE, Bedford, MA, Apr. 1992. (This document was prepared for authorized distribution. It has not been approved for public release.)
3. Sue, M. K., editor, *Personal Access Satellite System (PASS) Study*, JPL Internal Document D-7382, Jet Propulsion Laboratory, Pasadena, CA, Sept. 1990.
4. Naderi, F., editor, *Lund Mobile Satellite Service (LMSS): A Conceptual System Design and Identification of the Critical Technologies*, JPL Publication 82-19, Jet Propulsion Laboratory, Pasadena, CA, Feb. 1982.
5. Harrington, R. F., Bailey, M. C., Kendall, B. M., Schroeder, L. C., Lawrence, R. W. and Campbell, T. G., "Microwave Radiometer Sensor Technology Research for Earth Science Measurements," presented at the 1993 SPIE International Symposium on Optical Engineering and Photonics in Aerospace and Remote Sensing, Orlando, FL, Apr. 12-16, 1993.
6. Theon, J. S., Summary Report of the "Low Earth Orbit Microwave Radiometry Workshop," sponsored by the **Office** of Space Science and Applications, NASA Headquarters, Radisson Hotel, Hampton, VA, Sept. 22-24, 1992.
7. Stutzman, W.L., and Brown, G. S., *The Science Benefits of and The Antenna Requirements for Microwave Remote Sensing from Geostationary Orbit*, NASA Contractor Report 4408, prepared for NASA Langley Research Center, Hampton, VA, Oct. 1991.
8. Garrett, L. B., editor, *Global Change Technology Architecture Trade Study*, NASA TM-104128, 1991.
9. Rogers, C. A., Stutzman, W. L., Campbell, T. G. and Hedgepeth, J. M., "Mission to Planet Earth Technology Assessment and Development for Large Deployable Antennas," presented at the International Astronautical Federation, Dresden, GDR, Oct. 1990.

10. Campbell, T. G., editor, *NASA Workshop on Earth Sensing Geostationary Platform Technology*, Conference Proc. Publication 3040, NASA Langley Research Center, Hampton, VA, Sept. 1988.
11. Gasiewski, A. J., and Staelin, D. H., "Science Requirements for Passive Microwave Sensors on Earth Science Geostationary Platforms," *Proc. of the Workshop on Earth Science Geostationary Platform Technology*, NASA Conference Publication 3040, NASA Langley Research Center, Hampton, VA, 1988.
12. Lawrence, R. W., Bailey, M. C., Harrington, R. F., Hearn, C. P., Wells, J., and Stanley, 2W. D., *Design and Development of a Multiple Beam 1.4 Ghz Pushbroom Microwave Radiometer*, NASA TM 86390, Aug. 1985.
13. Ulvestad, J. S., "Advanced Space VLBI Mission Concept," to be presented at the International Union of Radio Science and International Astronautical Union Sponsored VLBI Symposium, Kyoto, Japan, Sept. 6-10, 1993.
14. Levy, G., editor, *Workshop Proceedings: Technologies for Advanced Very Long Baseline Interferometry Missions in Space*, JPL Internal Document JPL D-8541, vol. 3, Jet Propulsion Laboratory, Pasadena, CA, Sept. 15, 1991.
15. Freeland, R. E., *QUASAT Antenna Technology Study*, JPL Internal Document D-3292, Jet Propulsion Laboratory, Pasadena, CA, Sept. 1986.
16. Freeland, R. E., "Survey of Deployable Antenna Concepts," *Large Space Antenna Systems Technology - 1982*, NASA Conf. Pub. 2269, Part 1, NASA Langley Research Center, Hampton, VA, pp. 381-421, Dec. 1982.
17. Jordan, J. F., Freeland, R. E., Levey, G. S., and Potts, G. L., "QUASAT - An orbiting Very Long Baseline Interferometer Program Using large Space Antenna Systems," *Large Space Antenna Systems Technology - 1984*, NASA Conf. Pub. 2368, Part 1, NASA Langley Research Center, Hampton, VA, pp. 117-126, Dec. 1984.
18. S. S. Weinstein, "Pluto Flyby Mission Design Concepts for Very Small and Moderate Spacecraft," AIAA Paper 92-4372, AIAA/AAS Astrodynamics Meeting, Hilton Head, SC, Aug. 10-12, 1992.
19. Freeland, R. E., "Mobile Communications Satellite Antenna Flight Experiment Definition," IAF paper 87-314, presented at the 38th IAF International Astronautical Congress, Brighton, England, Oct. 10-17, 1987.
20. Mankins, J. C., Dickinson, R. M., Freeland, R. E., Marzwell, N. I., "Large Space Reflector Technology on the Space Station," AIAA Paper 86-2302, presented at Space Station in The Twenty-First Century, Reno, NV, Sept. 5, 1986.
21. Freeland, R. E., "Deployable Antenna Concept Development," presented at the AIAA Space Systems Technology Workshop III, Kirkland, Air Force Base, Albuquerque, NM, Mar. 1984.
22. Springett, J., Freeland, R., Smith, J. G., and Woo, K., "Large Deployable Antenna Shuttle Experiment," presented at the American Astronautical Soc. Twenty-First Arm. Meeting on Space Shuttle Missions of the 80s, Denver, CO, Aug. 1975.
23. Clark, L. G., "A Look at NASA's IN-SPACE Technology Experiment Program," presented at the Canaveral Council of Technical Societies, Twenty-Seventh Space Congress, Cocoa Beach, FL, Apr. 1990.
24. Thomas, M., "Flight Experiment for Large Inflatable Parabolic Reflector," presented at the ASME International Solar Energy Conference, Washington, DC, Apr. 4-9, 1993.
25. Freeland, R. E., and Bilyeu, G., "IN-STEP Inflatable Antenna Experiment," IAF Paper 92-0301, presented at the 43rd Congress of the International Astronautical Federation, Washington, DC, Aug. 28-Sept. 5, 1992.